

Water Diversion Valve

BAS25 Installation & Operating Instructions

- ✓ Hydraulically Operated
- ✓ Solid Brass Construction
- ✓ Built-in Dual Check Valves

 acquasaver.com.au



Introduction

The AcquaSaver Valve is a fully automatic adjustable mechanical rainwater/mains water changeover device designed for pressure pump supply systems for harvesting rainwater for the toilet, laundry and household applications with automatic mains backup. It is suitable for up to Multiple toilets and washing machine & taps.

Features

- ✓ Easy to install
- ✓ Patent design
- ✓ Solid Brass mounting bracket (optional)
- ✓ Watermark approved to WMTS-477:2016
- ✓ Does not require regular maintenance
- ✓ No electrical consumption - No electronic components
- ✓ Solid brass construction - Fully weatherproof - Built to last
- ✓ Suitable for any pressure pump with sufficient head pressure
- ✓ Can be mounted in any position
- ✓ Dual Outlets
- ✓ Built-in dual check valve for backflow prevention
- ✓ 3 Year warranty

Specifications

Max Mains Pressure	1000 KPa
Min Pump pressure	350 KPa
Max Flow Rate	100 LPM
Max Water Temperature	50° C
Min Water Temperature	0° C *
Pump Inlet	25mm 1" BSP F
Mains Water in	25mm 1" BSP F
Outlets	25mm 1" BSP F
Weight	1.6 KG

*Ensure proper protection against freezing weather. Complies to AS/NZS 3500.1 when installed by a licensed plumber.

Operation

The AcquaSaver Valve will always prioritise the use of rainwater over mains water when rainwater is available and will automatically switch over to mains water in the event of the rainwater tank running low or electrical failure.

When rainwater has been replenished, or power has been restored to the pump, the AcquaSaver valve will automatically prioritise back to rainwater.

The pump is only active when rainwater is being drawn from the water tank, it does not operate when the AcquaSaver Valve has switched to mains position.

The pump controller starts and stops the pump when it detects a demand - for example flushing a toilet or using a washing machine.

The operating mechanism of the AcquaSaver Valve is a unique patent design, it works by hydraulic water pressure created by the pump to close one inlet fully before opening the other inlet, This ensures an extremely reliable mechanism using few moving parts and no electronic components and no energy consumption.

Maintenance

The AcquaSaver Valve does not require any regular maintenance; however, there are things you can do to ensure its most reliable operation:

- Fit a Y-Strainer
- Cleaning your gutters
- Cleaning the inlet strainer on rainwater tank

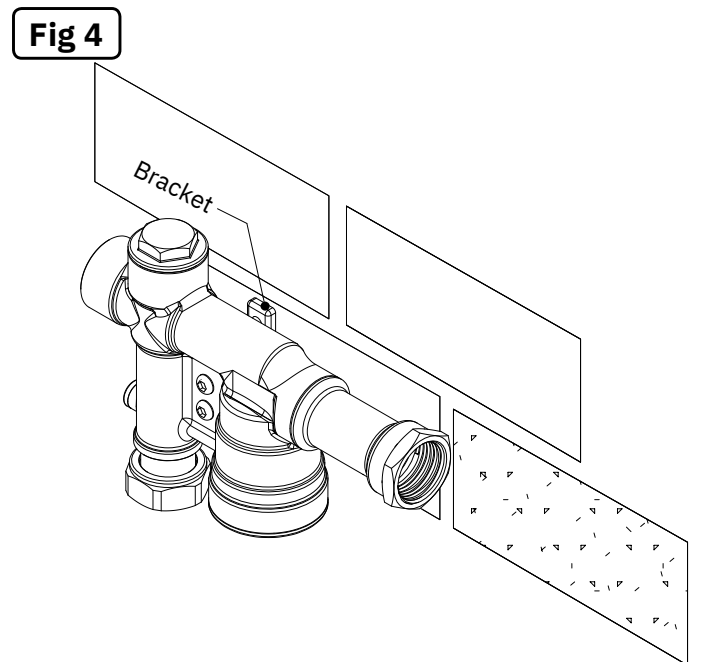
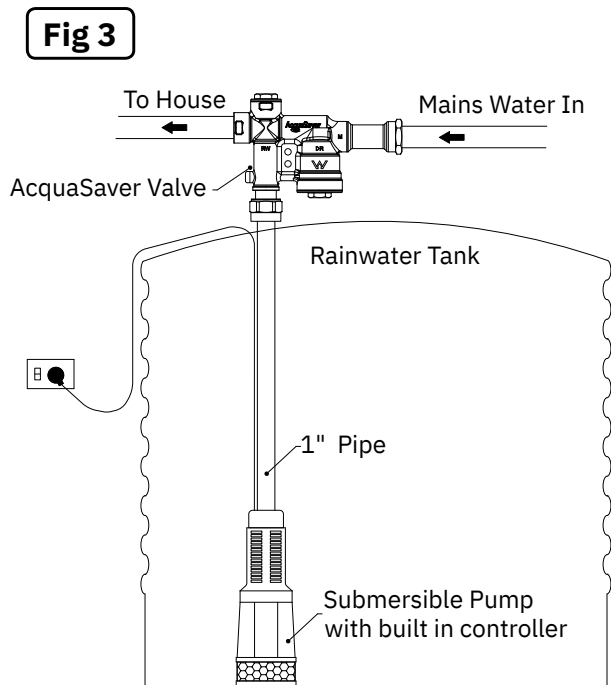
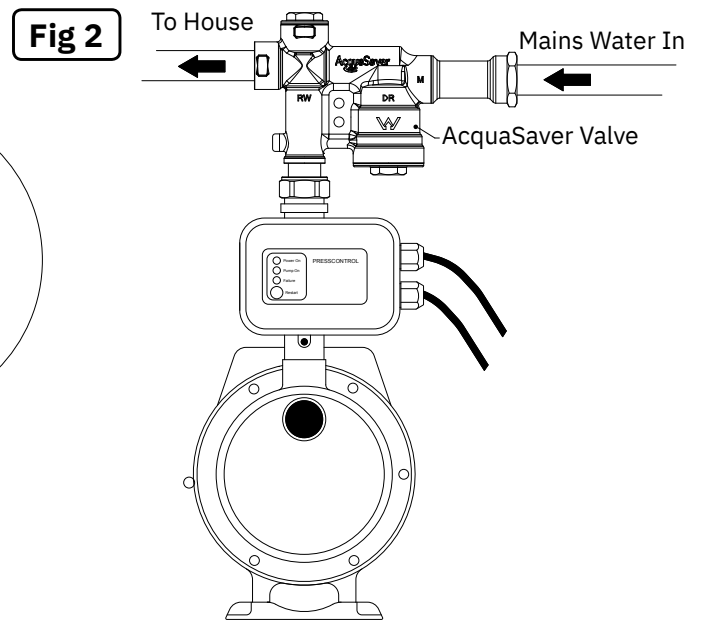
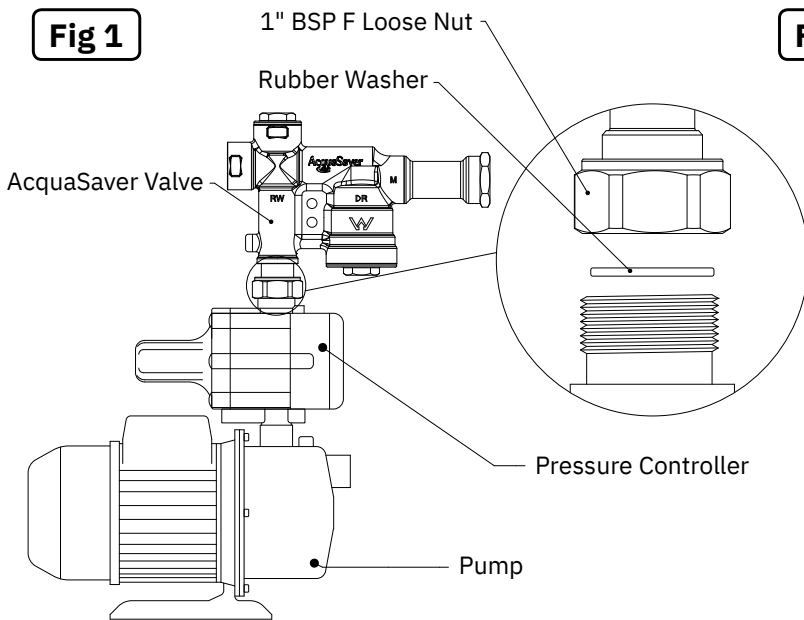

Connection

- STEP 1** The AcquaSaver Valve is fitted onto the pump controller as shown in [Fig 1](#). lock up the 1" BSP F loose nut with the rubber washer supplied, do not over tighten.
- STEP 2** Connect mains water to the AcquaSaver [Fig 2](#).
- STEP 3** Connect outlet to the household. [Fig 3](#) shows a typical installation for a submersible pump. [Fig 4](#) show the AcquaSaver mounted to a surface using an AcquaSaver bracket

NOTES:

- The AcquaSaver Valve can be installed in any position and location, it does not require to be installed on the pump as shown in the diagram.
- The connection of the pump should be carried out to manufacturers instructions, It is recommended a Y-Strainer be fitted between the tank and pump.
- Pump needs to be primed before use.

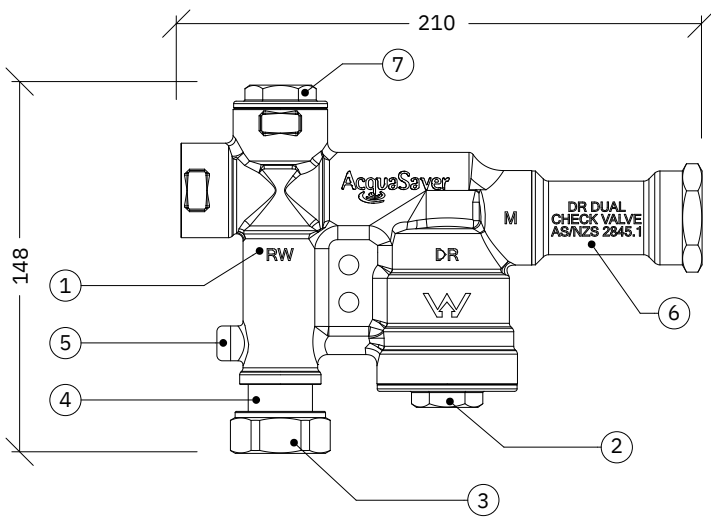

Parts List

No.	Component	QTY	Material	Part No.
1	AcquaSaver Body	1	DZR Brass	WDV25-D B
2	End Cap	1	DZR Brass	WDV25-D EC
3	DN25 Nut	2	Brass N/P	DN25 Nut
4	Brass Tail	1	DZR Brass	WDV20-S BT
5	1/8 BSP Plug	1	Stainless Steel	N/A
6	Dual Check Valve	1	DZR Brass	WDV25 DCV
7	DN25 End Cap	1	DZR Brass	DN25 EC

Trouble Shooting

Symptom	Cause	Remedy
No water is delivered from the pump or pump performance is decreased	The rainwater tank is empty. No Power. Isolation Valve is shut. The pump is not primed. Y-Strainer is blocked.	Wait for the tank to fill. Check power supply & plug. Restart pump. Open isolation Valve. See pump owners manual on priming pump. Clean Y-Strainer.
No water is delivered from mains	No water from mains. Debris in valve Air Lock	Check isolation valve on the water meter. Open bleed plug
Pump continually runs	Leak in the plumbing system. E.g. Toilet or tap leaking. Faulty pump	Repair Leak Contact pump manufacturer

AcquaSaver warranty for Australia and New Zealand

The AcquaSaver valve is guaranteed for 3 years from the date of original purchase to be free of material or manufacturing defects. Should any part fail as a result of such defects within this period, the AcquaSaver valve will be repaired or replaced free of charge. The AcquaSaver valve also has a LIMITED LIFETIME WARRANTY on all brass components; any brass components will be replaced free of charge if it fails in normal use during its life. This warranty applies to all states and territories in Australia and New Zealand. The warranty period commences on the day of the original purchase of the AcquaSaver valve. Evidence of this purchase must be provided when claiming repairs or replacement; it is recommended you retain all receipts. Both warranties are subject to conditions by the original purchaser with all conditions set out in the installation and operating instructions. Failure to comply with these instructions, damage or breakdown caused by fair wear and tear, negligence, misuse, incorrect installation, chemical or additives in the water, corrosive or abrasive water, inadequate conditions, attempting repairs or accidents, are not covered by this warranty.



1300 4 BBENG
www.brownbros.com.au



0508 4 BBENG
www.brownbros.co.nz