

P (PK) 30 - 40 - 60 - 70

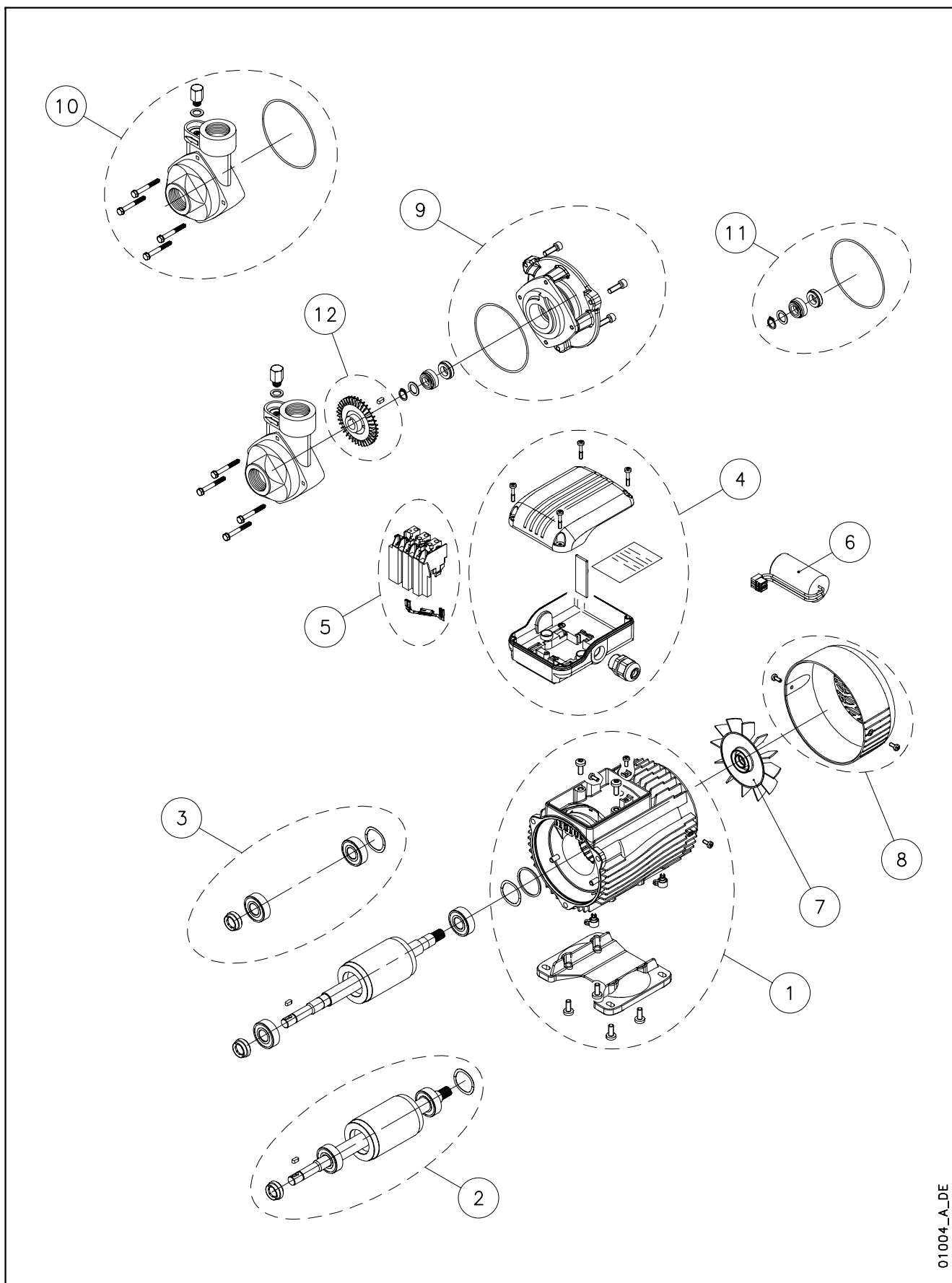

01004_A_DE

Lowara is a trademark of Xylem Inc. or one of its subsidiaries.

N.	Descrizione – Description - Description – Beschreibung – Descripción – Descrição
1	Cassa motore con statore – Motor casing and stator – Casse moteur avec stator – Motorgehaeuse mit stator – Caja motor con estator – Carcada do motor com estator
2	Albero rotore + cuscinetti – Rotor shaft + bearings – Rotor arbre + roulements – Rotor mit welle + lagern – Rotor arbol + cojinetes – Rotor veio + rolamentos
* 3	Cuscinetti – Bearings – Roulements – Lagern – Cojinetes – Rolamentos
4	Scatola morsettiera – Terminal box board – Boite a bornes – Klemmkastenbrette – Caja tablero de bornes – Caixa quadro de grampo
5	Morsettiera (Plug-in) – Terminal block (Plug in) – Bornier enfichable (Plug in) – Steck-Klemmkasten (Plug in) – Place de bornes (Plug in) – Grampo (Plug in)
6	Condensatore – Capacitor – Condensateur – Kondensator – Condensador – Condensador
7	Ventola – Fan – Ventilateur - Ventilator – Ventilador – Ventoiinha
8	Copriventola – Fan cover – Protection ventilateur – Ventilatorabdeckung – Proteccion ventilador – Proteccao de ventoiinha
9	Supporto motore/pompa + OR – Motor/pump bracket + O ring – Support moteur/pompe + joint torique – Motor/Pumpen Halterung + O-Ring – Soporte de motor/bomba + torico - Suporte do motor/bomba + O-Ring
10	Corpo pompa + OR – Pump body + O ring – Corps de pompe + joint torique – Pumpengehäuse + O-Ring – Caja bomba + tórico – Corpo da bomba + O ring
* 11	Kit tenuta meccanica e guarnizioni OR – Mechanical seal and O ring kit – Kit Garniture d'étanchéité mécanique au joints toriques – Dichtungssatz und O-Ring – Kit retén mecánico y empaquetaduras aro tórico – Vedante mecânico e Kit Oring
12	Girante e linguetta – Impeller et key – Turbine et clavette – Laufrad und passfeder– Rueda de álabes y lengüeta – Impulsor e lingueta

* Parti di ricambio consigliate – Recommended spare parts – Pièces de rechange conseillées– Empfohlene Ersatzteile – Piezas de repuesto aconsejadas – Peças de reposição aconselhadas

PKM30/B - PKM40/B

PK30/B - PK40/C

KIT	DESCRIZIONE DESCRIPTION	MODELLO POMPA - PUMP-MODEL				
		PKM30/B	PK30/B		PKM40/B	PK40/C
		107490630	TBD		107490640	TBD
		0.55 kW	0.55 kW		0.75 kW	0.75 kW
		SM			SM	SM IE2
1	CASSA MOTORE MOTOR CASING	KR7491000	KR7491010		KR7491020	KL25AC6
2	ALBERO-ROTORE-CUSCINETTI SHAFT-ROTOR-BEARINGS	KR7491040	KR7491060		KR7491050	KL09ABU
* 3	CUSCINETTI BEARINGS	KR7491080	KR7491080		KR7491080	KL11AAC
4	SCATOLA MORSETTIERA TERMINAL BOX	KR7491090	KR7491100		KR7491090	KR7491100
5	MORSETTIERA PLUG IN PLUG IN BLOCK	KR7491120	KR7491110		KR7491130	KR7491110
6	CONDENSATORE CAPACITOR	KR7491140	-		KR7491150	-
7	VENTOLA FAN	140760150	140760150		140760150	140760160
8	COPRIVENTOLA FAN COVER	KR7491170	KR7491170		KR7491170	KL29AAE
9	SUPPORTO MOTORE/ POMPA + OR MOTOR/PUMP BRACKET + OR	KR7491200	KR7491200		KR7491210	KL16AAS
10	CORPO POMPA + OR PUMP BODY + OR	KR7491240	KR7491240		KR7491250	KR7491250
* 11	KIT TENUTA + OR BVEFF SEAL + OR	KR7491280	KR7491280		KR7491290	KR7491290
	KIT TENUTA + OR BVVFF SEAL + OR	KL01AEE	KL01AEE		KL01AEF	KL01AEF
	KIT TENUTA + OR AEVGFF SEAL + OR	KL01AEK	KL01AEK		KL01AEL	KL01AEL
	KIT TENUTA + OR U3U3VFF SEAL + OR	KL01AEG	KL01AEG		KL01AEH	KL01AEH
12	GIRANTE ACQUA 80°C IMPELLER WATER 80°C	KR7491320	KR7491320		KR7491330	KR7491330
	GIRANTE OLIO DIATERMICO IMPELLER DIATHERMIC OIL	KR7491340	KR7491340		KR7491350	KR7491350

* RICAMBI RACCOMANDATI
RECOMMENDED SPARE PARTS

xylem