

**CentriPro PC PLUS  
Automatic  
Pump Controller  
Installation, Operation  
and Maintenance  
Manual**



**CentriPro**  
a xylem brand

Australia  
Phone: 13 19 14  
Email: [enquiriesau@xylem.com](mailto:enquiriesau@xylem.com)  
[www.xylem.com/au](http://www.xylem.com/au)

New Zealand  
Phone: 0800 33 19 14  
Email: [enquiriesnz@xylem.com](mailto:enquiriesnz@xylem.com)  
[www.xylem.com/nz](http://www.xylem.com/nz)



RCM  
Compliant



AS4020 Certified  
Suitable for  
Drinking Water

# CentriPro PC PLUS Automatic Pump Controller

## Installation, Operation and Maintenance Manual

.....

### CONGRATULATIONS!

You are now a proud owner of a quality CentriPro product. For best results, please read this Installation, Operation and Maintenance (IOM) carefully before installing and using this product.



### TABLE OF CONTENTS

Specifications .....	2
Safety Precautions .....	3
Installation .....	4
Wiring Diagram .....	4
Assembly Instructions .....	6
Electrical Connection .....	7
Unit Starting and Working .....	8
Trouble Shooting Guide .....	9
PC PLUS Dimensional Drawing .....	10
CentriPro Limited Warranty .....	12

### SPECIFICATIONS

Input voltage	220- 240 V
Frequency	50/60 Hz
Maximum working pressure PC PLUS	12 Bar
Maximum working temperature	65°C
Maximum Current PC PLUS	10A
Connection	1" male
Protection rating	IP65
Pre-set Pressure PC PLUS	1.5 to 2.2 Bar

## SAFETY PRECAUTIONS

This symbol    together with one of the following words "Danger" or "Warning" indicates the risk level deriving from failure to observe the prescribed safety precautions:



**DANGER: Warns that failure to observe the precautions involves a risk of damage to persons and / or things.**

---



**DANGER: Risk of electrical shock. Warns that failure to observe the precautions involves a risk of electric shock.**

---



**WARNING: Warns that failure to observe the precautions involves a risk of damaging the product.**

---



Make sure that the mains voltage corresponds to the voltage specified on the faceplate and the reference characteristics (frequency, and input current) are shown in this IOM.



The connections to the mains and grounding must be executed by qualified personnel and in compliance with local installation standards. Open the terminal (front) box lid and carry out connections as per the diagram on it.

Pay attention to the working limits. Improper use may damage the controller and other property, and injure people.



Make sure that the rated voltage and the mains voltage are compatible.



Connect to the power mains using a multi-pole power with a switch-contact gap of at least 3 mm. As additional protection from lethal electric shock, install a high-sensitivity differential "RCD/Earth-Leakage" switch.

Make sure unauthorised people do not have access to the unit. Disconnect the power supply to the unit or unplug the machine before carrying out any maintenance, cleaning or handling operations. If the power cord is damaged it must be replaced by qualified personnel to ensure against hazards.

Be alert to hazardous situations caused by accidental power failure.

Make sure the unit is properly ventilated. Warning: the motor can reach a temperature of 95°C.

# INSTALLATION

If the column of water between the pump and the highest tap exceeds 15m (static discharge head of 15m), the unit cannot be installed directly on to the pump. The unit has to be raised until the column of water between the unit and the highest tap does not exceed 15m. I.E. if the column of water is 20m above the pump, the unit must be placed 5m higher than the pump, or have to use a 2.2 Bar restarting/cut-in pressure device.

The unit is equipped with a check valve to assist preventing the pipeline from losing pressure.

No taps or outlets can be installed between the pump and the unit.

## PUMP PRESSURE

The PC PLUS is pre-set by the manufacturer to have a restarting/cut in pressure of either 1.5 to 2.2 Bar.

To use the PC PLUS the pressure produced by the pump must be at least 3 Bar.

Prior to operation, check unit and pump are compatible.

Before starting the unit, check suction and ensure that the pump is primed.

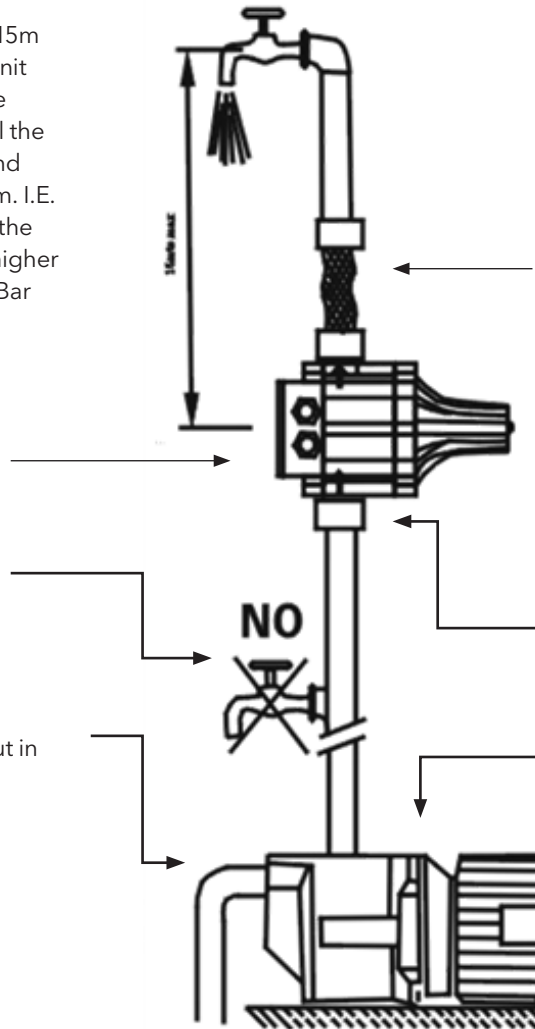

It is advisable to connect the units outlet to the system by means of a flexible hose.

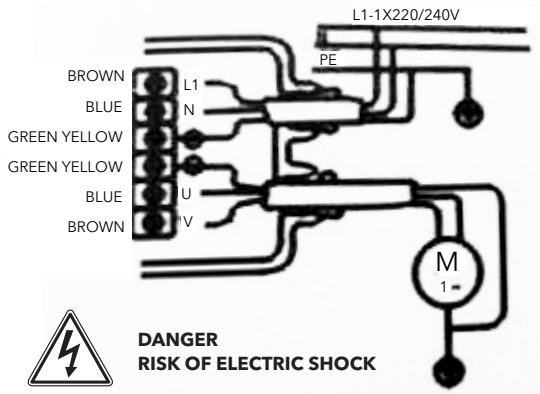

### Wiring Diagram

Wiring Diagram for connection of single phase 220/240V pumps up to 1.5 kW for PC PLUS

### DO NOT TOUCH

Safety valve prevents water emission in case of diaphragm breakage.

It is imperative to install the unit with the arrows in the upward position.

The unit is designed to be installed directly on to the pump, or between the pump and the first tap.



**This product is not weatherproof.**

**Do not install in direct sunlight.**

## ASSEMBLY INSTRUCTIONS

- 1** Secure the pump on a flat even surface.
- 2** Screw the barrel union provided into the discharge port of the pump.
- 3** Place the O Ring into the recess of the barrel union discharge.
- 4** Screw the PC PLUS Press Control into the discharge of the barrel union by holding the PC PLUS steady and rotate the barrel union anti clockwise until secured.
- 5** The PC PLUS is now secured to the pump and ready to operate.

### Special Note

The PC PLUS is factory fitted with plug and play power leads which connect directly to the matching leads as fitted to the pump. These leads are a press fit by hand and do not require the services of an electrician.

The power lead to the wall socket is supplied with the pump.

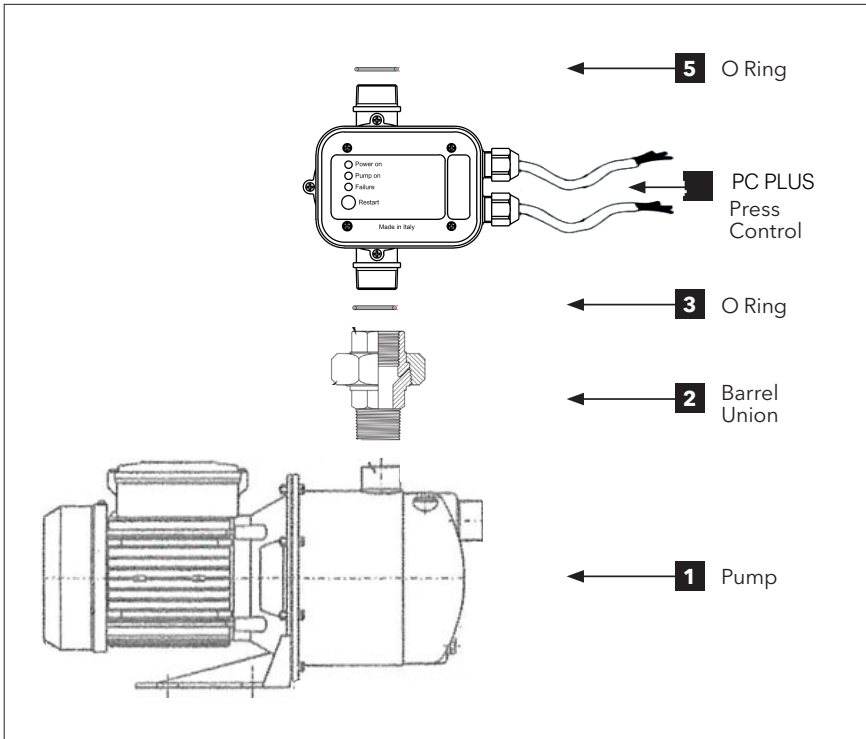

## ELECTRICAL CONNECTION AND STARTING



Failure to comply may cause unit and/or pump failure



**WARNING**

Never take the electronic board out of the control box.



The wiring diagram inside the terminal block indicates how to make the correct connection. Incorrect connections will destroy the electronic circuit.



The cable used for connection must be three-wire with a compulsory ground.



The cable outer diameter should be 7.5mm minimum and 10.5mm maximum. One of the leading ends of the cable must be lower than the position of the fixing screws while the cable is being connected to the power as shown in Fig.1



The four screws fastening the panel board and the two cable stands for fixing cable must be well fastened to avoid water entering the control box and damage electronic circuit.

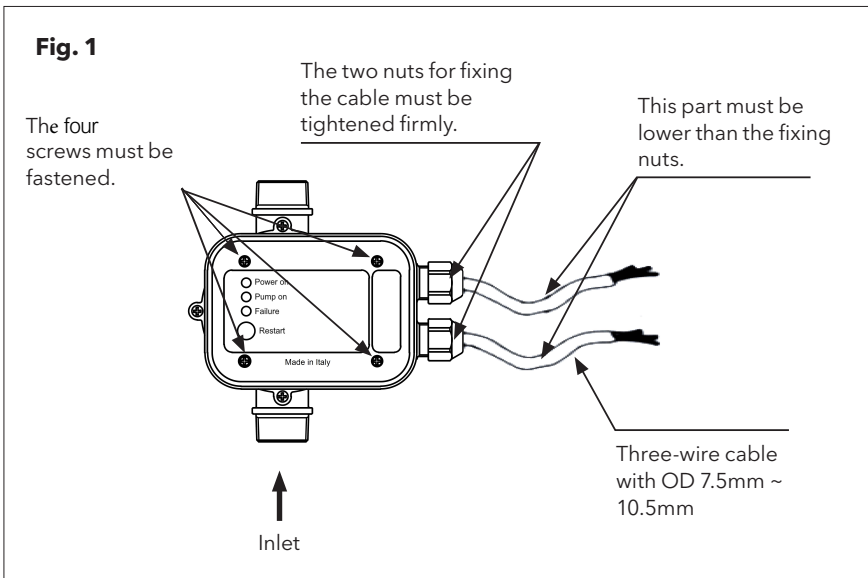

## INSTALLATION AND STARTUP

The device can be installed directly on the pump or between the pump and the first tap. Make all the electrical connections, check that the pump is correctly primed, open a tap and energize. From now on, the device will turn the pump on and off depending on the opening and closing of the tap. In case of water shortage, the device will stop the pump and protect it from dry running (red "Failure" led blinking). In case of a temporary blackout, the device will automatically rearm once the electricity returns.

## AUTOMATIC RESTART/REARM

In case of stopping due to a water shortage, the device will automatically make 10 double attempts to rearm over the 24 hours following the failure, each lasting approximately 5 seconds to allow the pump and the system to reload if possible.

After the last failed rearming attempt, the device will remain permanently in alarm (red Failure LED blinking) pending manual rearming by pressing the "Restart" button.

The user can always try to rearm the device at any time by pressing the Restart button.

After 24 hours it will make a single rearming attempt of 5 seconds, and if in this case it finds water it will reset and repressurise the system but if it will not find water it will return in failure and will try to rearm again after 24hrs.

If water returns at any time during the rearming procedure, the device will automatically restart.

The simplified time sequence of the double rearms is as follows:

1 <sup>st</sup>	rearm attempt after failure	10 sec.
2 <sup>nd</sup>	rearm attempt after the previous attempt	20 sec.
3 <sup>rd</sup>	rearm attempt after the previous attempt	15 sec.
4 <sup>th</sup>	rearm attempt after the previous attempt	30 sec.
5 <sup>th</sup>	rearm attempt after the previous attempt	1 hr
6 <sup>th</sup>	rearm attempt after the previous attempt	2 hr
7 <sup>th</sup>	rearm attempt after the previous attempt	3 hr
8 <sup>th</sup>	rearm attempt after the previous attempt	4 hr
9 <sup>th</sup>	rearm attempt after the previous attempt	5 hr
10 <sup>th</sup>	rearm attempt after the previous attempt	6 hr

## ANTI-JAMMING FUNCTION

If for any reason the pump remains idle for 24 consecutive hours, the device will carry out a start-up of the pump for about 5 seconds (anti-jamming function).



## TROUBLESHOOTING GUIDE

PROBLEM	POSSIBLE CAUSE	SOLUTION
<b>The pump does not start</b>	- System is already under pressure	- Closed Tap. - The column of water over the device is higher than the restart pressure of the device.
	- Faulty pump capacitor	- Check pump capacitor.
	- Pump is jammed	- Remove the object mechanically jamming the pump .
	- Front pannel led lights are off	- Check power supply. - Check wiring. - Electronic card may be broken.
<b>The pump does not stop</b>	- Device installed in horizontal position	- Install the device in vertical position.
	- Presence of flow	- Check if any tap is open and in that case close it.
	- Tap closed and presence of a big expansion tank	- In this case, the pump will stop the pump in a longer time; that depends on the pressure tank size and its pressure.
	- System leaks higher than the minimum flow	- Check if there are leaks in the system.
	- Flow valve blocked in the upper position	- Check the presence of foreign bodies in the device.
<b>Intermittent pump working</b>	- Presence of system leaks lower than the minimum flow of 1 L/min	- Check if there are leaks in the system.
	- Pressure generated from the pump is too low	- The pump is not compatible with the restart pressure of the device. - The pump is old and has lost efficiency compared to the pumps specifications.
	- Pump is discharged	- Check the correct priming of the pump. - Presence of air in the system.

# PC PLUS DIMENSIONAL DRAWING

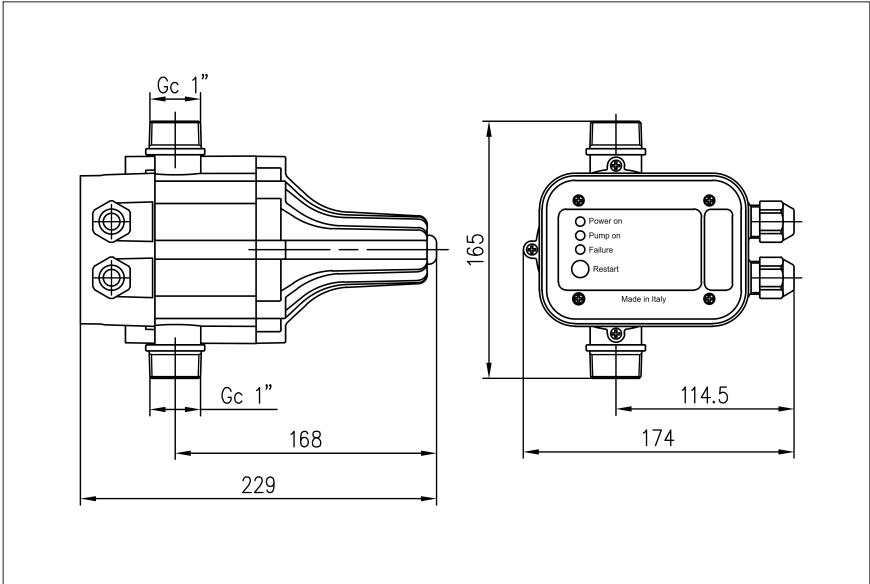



## CENTRIPRO LIMITED WARRANTY

This warranty applies to all pumps and related accessories manufactured and/or supplied by CentriPro, provided the installation is in accordance with the Instruction Manual issued by the Manufacturer.

Any part or parts found to be defective within the warranty period shall be replaced at no charge to the buyer or any subsequent owner during the warranty period. The warranty period shall exist for a period of twelve (12) months from the date of installation or eighteen (18) months from the date of manufacture, whichever is shorter.

A consumer who believes that a warranty claim exists must contact the authorised CentriPro dealer from whom the equipment was originally purchased and furnish complete details regarding the claim for warranty. This warranty excludes:

- a. Labor, transportation and related costs incurred by the consumer to make the alleged defective equipment available to the dealer for inspection.
- b. Re-installation costs of repaired equipment.
- c. Re-installation costs of replacement equipment.
- d. Consequential damages of any kind.
- e. Reimbursement for loss caused by interruption of service.

There are no warranties, expressed or implied, except such warranties as are definitely set forth herein. The company shall not be liable for damage or wear to pump caused by abnormal conditions, failure to properly prime or to operate pump without flow or caused by corrosives, abrasives, or foreign objects. No obligations other than those herein set forth shall be binding upon the company.



**AS4020 Certified  
Suitable for  
Drinking Water**



1300 4 BBENG  
[www.brownbros.com.au](http://www.brownbros.com.au)

CentriPro is a trademark of Xylem Inc. or one of its subsidiaries.

AU ED 03/2021 (Australian Edition)