

it	POMPE SOMMERSE SERIE Z6	Istruzioni d'installazione e uso
en	SUBMERSIBLE PUMPS Z6 SERIES	Installation and operating instructions
fr	POMPES IMMERGÉES SÉRIE Z6	Instructions pour l'installation et l'emploi
de	TAUCHPUMPE / UNTERWASSERPUMPE BAUREIHE Z6	Installations- und Bedienungsanleitungen
es	BOMBAS SUMERGIBLES SERIE Z6	Instrucciones para la instalación y el uso
pt	BOMBAS SUBMERSÍVEIS SÉRIE Z6	Instruções de instalação e uso
el	ΥΠΟΒΡΥΧΙΕΣ ΑΝΤΛΙΕΣ ΣΕΙΡΑ Z6	Οδηγίες εγκατάστασης και χρήσης
nl	DOMPELPOMPEN Z6 SERIE	Aanwijzingen voor de installatie en het gebruik
da	DYKPUKPER SERIE Z6	Manual vedrørende installation og brug
no	NEDSENKBARE PUMPER SERIE Z6	Håndbok for installasjon og bruk
sv	DRÄNKBARA PUMPAR I SERIE Z6	Bruks- och underhållsanvisning
fi	UPPOPUMPUT Z6-SARJA	Asennus- ja käyttöohjeet
ar	مضخات مغمورة طراز Z6	تعليمات التركيب و الاستخدام
pl	POMPY GŁĘBINOWE 6" SERII Z6	Instrukcja obsługi i eksploatacji
hu	MERÜLŐSZIVATTYÚK Z6 SOROZAT	Telepítési és használati kézikönyv
ru	ПОГРУЖНЫЕ НАСОСЫ СЕРИИ Z6	Инструкция по монтажу и эксплуатации
tr	Z6 SERİSİ ELEKTRİKLİ DALGIÇ POMPALAR	Montaj ve kullanım talimatları

	it	Conservate con cura il manuale per future consultazioni
	en	Keep this manual for future reference
	fr	Conservez avec soin le manuel pour toute consultation future
	de	Die Bedienungsanleitung muss für zukünftige Konsultationen sorgfältig aufbewahrt werden
	es	Guardar con cuidado el manual para poderlo consultar en el futuro
	pt	Conservar cuidadosamente o manual para consultas futuras
	el	Διατηρήστε με επιμέλεια το εγχειρίδιο για μελλοντικές συστάσεις
	nl	Bewaar de handleiding zorgvuldig voor latere raadpleging
	da	Gem manualen til senere brug
	no	Les håndboken før bruk og oppbevar den med omhu
	sv	Spara bruksanvisningen för framtida bruk
	fi	Säilytä käyttöopas huolellisesti
	ar	احتفظوا بكتيب التعليمات للرجوع إليه مستقبليا
	pl	Przeczytaj tą instrukcję dla przyszłej obsługi
hu	Hu Gondosan őrizze meg a kézikönyvet jövőbeni szükség esetére	
ru	Храните это руководство для возможных консультаций	
tr	Lütfen bu el kitabını ileride başvurmak üzere güvenli bir biçimde saklayınız	

it AVVERTIMENTI PER LA SICUREZZA DELLE PERSONE E DELLE COSE

Di seguito trovate il significato dei simboli utilizzati nel presente manuale



PERICOLO

Rischio di danni alle persone, e alle cose, se non osservate quanto prescritto



SCOSSE ELETTRICHE

Rischio di scosse elettriche se non osservate quanto prescritto



AVVERTENZA

Rischio di danni alle cose (pompa, impianto, quadro,...) o all'ambiente se non osservate quanto prescritto



Leggete attentamente il manuale prima di procedere

Informazioni per:

il trasportatore

Informazioni specifiche per chi trasporta, movimenta, immagazzina il prodotto

l'installatore

Informazioni specifiche per chi procede all'installazione del prodotto nell'impianto (per la parte idraulica e/o elettrica)

l'utilizzatore

Informazioni specifiche per chi usa il prodotto

il manutentore

Informazioni specifiche per chi cura la manutenzione del prodotto

il riparatore

Informazioni specifiche per chi ripara il prodotto

1.	Generalità.....	pag.	11
2.	Descrizione del prodotto.....		11
3.	Impieghi.....		11
4.	Trasporto e immagazzinamento.....		12
5.	Installazione.....		13
6.	Messa in funzione.....		13
7.	Manutenzione, assistenza, ricambi.....		14
8.	Ricerca guasti.....		15
9.	Dismissione.....		16
10.	Tabelle e disegni.....		107

en WARNINGS FOR THE SAFETY OF PEOPLE AND PROPERTY

Meaning of the symbols used in this manual



DANGER

Failure to observe this warning may cause personal injury and/or damage to property



ELECTRIC SHOCK

Failure to observe this warning may result in electric shock



WARNING

Failure to observe this warning may cause damage to the pump, system, panel or environment



Read the manual carefully before proceeding

Information for:

carriers

Specific information for carriers, handlers and warehouse personnel

installers

Specific information for personnel in charge of installing the product in the system (plumbing and/or electrical aspects)

users

Specific information for users of the product

maintenance personnel

Specific information for personnel in charge of maintenance

repair personnel

Specific information for repair personnel

1.	Overview.....	page	17
2.	Product description.....		17
3.	Applications.....		17
4.	Transportation and storage.....		18
5.	Installation.....		19
6.	Start-up.....		19
7.	Maintenance, service and spare parts.....		20
8.	Troubleshooting.....		20
9.	Disposal.....		21
10.	Tables and Drawings.....		107

1. Overview

The purpose of this manual is to provide the necessary information for proper installation, operation and maintenance of the pumps/electric pumps in the Z6 Series. The contents of this manual concern the standard product, as described in the sale documents. Special versions may be supplied with supplementary instructions leaflets. Please refer to the sale contract for any modifications or special version characteristics. Always specify the exact pump/electric pump type and identification code when requesting technical information or spare parts from our Sales and Service Department. For instructions, situations or events not considered in this manual or in the sale documents, please contact our Service Center nearest you.



Read this manual before installing and using the product.



Improper use may cause personal injury and damage to property, and lead to the forfeiture of the warranty coverage.

2. Product description

Information for installers and users

The Z6 range features 6" submersible electric pumps and pumps made of stainless steel, which may be coupled to submersible motors having shaft extension and coupling flange dimensions in compliance with NEMA MG 1-1987.

In the Z6 series, all the metal parts that are in contact with the water are made of stainless steel.

If you have purchased a pump without the electric motor, make sure the motor you use is suitable for coupling to the pump.

3. Applications

Information for installers and users

These pumps are suitable for use in civil and industrial water distribution systems, irrigation (agriculture, sporting facilities), and firefighting applications.

3.1 Working limits

3.1.1 How to read the pump's rating plate

The drawings in section 10.1 show the essential data found on the rating plate.

3.1.2 Pumped liquids, pressures, temperatures

This pump may be used to pump cold water.

Maximum permissible quantity of suspended sand: 100 g/m³.

WARNING

Do not use this pump to handle water containing solid and/or fibrous substances.



Do not use this pump/electric pump to handle flammable and/or explosive liquids. Quantities of sand exceeding the maximum permissible limit may cause damage to the pump.

Maximum operating pressure : variable, depending on the pump model

Liquid temperature :	- for the pump alone	Minimum 0 °C	Maximum + 60 °C
	- for the electric pump	Minimum §	Maximum §



§ The temperature varies depending on the type of motor coupled to the pump. Always refer to the motor instructions.

For special requirements, please contact our Sales and Service Department.

3.1.3 Minimum and maximum immersion depth

WARNING

Make sure that the minimum dynamic level of the liquid is at least 1 metre above the pump's delivery port. The presence of air could damage the pump.

Do not use the pump if cavitation occurs, as its internal components could be damaged.



Electric pump: the maximum immersion depth depends on the type of motor used. Always refer to the motor instructions.

3.1.4 Installation position

The pump may be installed in either the vertical or horizontal position.

WARNING

If the pump is placed horizontally, make sure to install a check valve along the delivery pipe near the pump.



If the electric pump is installed in an accessible position, suitable safety measures (such as protection screens) must be taken to prevent possible contact with the coupling when the pump/electric pump is in operation.



Electric pump: the possibility of horizontal installation depends on the type of motor coupled to the pump. Always refer to the motor instructions.

For special requirements, please contact our Sales and Service Department.

3.1.5 Minimum operating flow rate

To prevent overheating of the internal pump components, make sure that a minimum water flow is always guaranteed when the pump/electric pump is running.

WARNING

To prevent overheating, do not run the pump/electric pump with the on-off valve shut on the delivery side for longer than a few seconds.

3.1.6 Motor cooling (electric pump)



Always refer to the motor instructions.

3.1.7 Number of starts per hour (electric pump)



Always refer to the motor instructions.

3.1.8 Electrical equipment requirements (electric pump)



Always refer to the motor instructions.

3.1.9 Sound emission level

As the pump/electric pump is totally submerged, no noise propagates to the outside.

3.1.10 Special applications

WARNING

Please contact our Sales and Service Department for any situation other than the ones described, related to the nature of the liquid and/or the installation.

3.1.11 Improper use



If you use the pump/electric pump improperly, you may create dangerous conditions and cause personal injury and damage to property. Here are a few examples of improper use:

- pumping liquids that are not compatible with the pump construction materials
- pumping hazardous (toxic, explosive, corrosive) liquids
- pumping drinking liquids (wine, milk,.....)
- operating with water temperature outside the limits specified above.

3.2 Warranty

Please refer to the sale contract for any information.

4. Transportation and storage

Information for carriers

4.1 Transportation, handling and storage of packed product – Unpacking the product

The pumps/electric pumps are packed in cartons or wooden crates of different sizes and shapes.

WARNING

The cartons/crates are designed to be transported, handled and stored in the horizontal position. Protect the product against humidity, heat sources and mechanical damage (collisions, falls, ...).

Do not place heavy weights on the packed products and do not stack them.

If the pump/electric pump is not packed, place it on suitable supports in the horizontal or vertical position, so as to prevent misalignments and excessive bending which could cause damage to the pump/electric pump (see section 10.2).

Use the hooks provided on the head (see section 10.3).



Do not lift the electric pump by the motor cable.



Lift and handle the product carefully, using suitable lifting equipment. Observe all the accident prevention regulations in force.

Ambient temperature suitable for storage: ranging from -5°C to +40°C.

When you receive the electric pump, check the outside of the package for evident signs of damage. If the product bears visible signs of damage, notify our distributor within 8 days from the delivery date.

WARNING

If the pump/electric pump is put into storage after a period of activity, thoroughly clean the electric pump and dry the liquid end using a jet of forced air.

4.2 Disposal of packing materials

If you cannot utilize the packing materials for other purposes, dispose of them according to the sorted waste disposal regulations locally in force.

5. Installation

Information for installers



The installation operations must be carried out by qualified and experienced personnel.

Use suitable equipment and protections. Observe all the accident prevention regulations in force.

Always refer to the local and/or national regulations, legislation and codes in force relating to the selection of the installation site and the water and power connections.



Read this operating manual and the instructions for the motor that is to be coupled to the pump before proceeding with the installation. Keep all instructions for future reference. Take note of the operating limits specified in section 3.1.

5.1 Selecting the electric motor



If you buy the pump without motor and couple it to a motor other than those described in our catalogue, the safety of the unit must be guaranteed by the person making the coupling.

WARNING

The power of the motor must be greater or at least equal to that required by the pump to which the motor is to be coupled. If you use a motor other than a standard one, make sure that the axial thrust tolerated by the motor is greater than the maximum axial thrust generated by the pump.

Please contact our Sales and Service Department for additional information.

5.2 Selecting the electric control panel

The motors must be suitably protected against overload and short circuits.



Always refer to the motor manual and the instructions provided with the electrical panel.

WARNING

Avoid the possibility of dry running, i.e. the pump must not run without water inside it. Make sure that the electric panel is equipped with a dry running protection system.

6. Start-up

Information for installers



Read this operating manual and the instructions for the motor that is to be coupled to the pump before start-up. Keep all instructions for future reference.

If the product bears visible signs of damage, do not proceed with installation; contact our Sales and Service Department.

6.1 Motor-pump coupling

If the pump is not coupled to the motor, assemble the unit as follows:

- 1 Position the motor securely in the vertical position.
- 2 Make sure the motor shaft rotates freely.
- 3 Make sure that the pump shaft rotates freely; be careful not to damage the coupling groove.
- 4 Remove the cable guard from the pump after unscrewing the fastening screws.
- 5 Clean the coupling surfaces on the motor and the pump.
- 6 Lift the pump over the motor and align them on the same axis. The motor studs must be aligned with the corresponding holes on the motor support, and the motor cable outlets must be aligned with the corresponding seats found on the lower support of the pump.
- 7 Lower the pump slowly until it completely engages the grooved shaft of the motor in the coupling. If necessary, rotate the coupling slightly to facilitate the operation.
- 8 Tighten the fastening nuts and washers diagonally and in a uniform manner (for additional information refer to the motor instructions). For information on torque, consult section 10.5.
- 9 Secure the cable guard to the pump, passing the motor cable under the guard.

6.2 Splicing the motor cable to the drop cable

If necessary, splice the two cables using the heat-shrink or resin-filled method, or other suitable system.



Always refer to the instructions for the couplings.

After splicing the cables, check the electrical continuity of the phase wires and the ground cable.

6.3 Water connection

Screw the delivery pipe into the electric pump outlet, holding it by the head. The threaded section of the pipe must not be longer than the threading on the pump. The pipe must be screwed in tight to prevent its coming loose as a result of repeated pump starting and stopping. There are one or more dowels on the delivery port which, if screwed into the pipe, will help prevent its coming loose.



For safety reasons, if you are using plastic or flexible piping, secure the electric pump by means of a loose stainless steel cable, passing it through the safety hooks provided on the head.

There is a non-return valve in the head of the pump. An additional non-return valve should be installed in the delivery pipe to reduce water hammer, especially if the delivery pipe is long.

Secure the electric cable to the pipe by means of clamps placed at 2 or 3 meters intervals.

For more information refer to the diagram in section 10.4.

6.4 Positioning the electric pump

Lower the electric pump into the well carefully in order to prevent damage to the pump and, more especially, the electric cable. If the pump is installed in the vertical position, make sure that the motor does not rest on the bottom of the well or tank. If the electric pump is installed in a well, make sure that the distance between the bottom of the well and the lower end of the motor is at least 1 metre.

If the electric pump is installed in the horizontal position, make sure that the motor is at a safe distance from the bottom of the well and that the position of the head is not lower than that of the motor support.

For additional information see sections 3.1 and 10.4.

6.5 Electrical connection



The electrical connections must be performed by a qualified installation technician in compliance with the regulations in force.

WARNING

Make sure that the supply voltages and frequencies are suited to the characteristics of the electric motor.



Before proceeding, make sure that all the connections (even those that are potential-free) are voltage-free.



Always refer to the motor manual and to the instructions provided with the electric panel.

6.6 Starting the electric pump

For the first pump start-up, the on-off valve should be about one-third of the way open in order to reduce as much as possible the suction of sand that may be found in the well. If the water is turbid, close the valve some more until the water is clear.

6.6.1 Electric pump direction of rotation

The correct direction of rotation of the shaft is anti-clockwise when facing the delivery side of the pump. The correct direction is indicated by an arrow on the pump body. In the case of three-phase electric pumps, if a visual check of the rotation direction is not possible, proceed as follows.

Connect the electric pump and start it. Stop the pump. Reverse the direction of rotation of the motor by switching the position of two phase conductors. Start the electric pump. The correct direction is the one that delivers the highest pressure.

6.6.2 Checking the purity of the pumped water

After checking the correct direction of rotation, leave the valve about one-third of the way open and check whether the pumped water is clear and clean. If any sand is present, let the pump run until clean water is delivered.

Open the valve gradually and wait until the water runs clean again. If the water runs clean when the valve is completely open, it means that the electric pump is ready to be permanently connected to the distribution network.

7. Maintenance, service and spare parts

Information for maintenance personnel



Before performing any maintenance operations on the electric pump, make sure that the motor is voltage-free.



Maintenance operations must be performed by skilled and qualified personnel only. Use suitable equipment and protection devices. Observe the accident prevention regulations in force. If you need to drain the pump, make sure that the drained liquid does not cause damage or injuries.

The pump does not require any scheduled routine maintenance. Extraordinary maintenance may be necessary in order to clean the liquid end or replace any worn components.

Please contact our Sales and Service Department for any requests.



Always refer to the motor manual.

7.1 Spare parts

WARNING

Always specify the exact pump/electric pump type and identification code when requesting technical information or spare parts from our Sales and Service Department.



Use only original spare parts to replace any components. The use of unsuitable spare parts may cause malfunctions, damage and injuries.

8. Troubleshooting

Information for users and maintenance personnel

PROBLEM	PROBABLE CAUSE	POSSIBLE SOLUTION
The electric pump does not start. The main switch is on.	No power supply	Restore the power supply
	Triggering of thermal relay or motor protector found in the electric control panel.	Reset the thermal protector

	Pump or auxiliary circuits protection fuses blown	Replace fuses
	Triggering of protection device against dry running	Check the water level in the tank or well. If everything is in order, check the protection device and its connection cables
The electric pump starts up but the thermal protector is immediately triggered or the fuses blow	Power supply cable is damaged	Check the components and replace as necessary
	Electric motor short circuit	
	Thermal protector or fuses not suited to the motor current	
	Motor overload	Check the operating conditions of the electric pump and reset the protection
	Wrong rotation direction	Check the direction of rotation and, if necessary, exchange two phases in the electrical panel if the pump is a three-phase model, or check all the connections if it is a single-phase model
The electric pump starts up but, after a short period of time, the thermal protector is triggered or the fuses blow.	A phase in the power supply is missing	Check the power supply
	Power supply voltage not within the motor's working limits	Check the operating conditions of the electric pump
	The electric panel is situated in an excessively heated area or is exposed to direct sunlight	Protect the panel from heat sources and from the sun
The electric pump starts up but, after a varying period of time, the thermal protector is triggered.	There are foreign bodies (solid or fibrous substances) inside the pump, the impellers are jammed	Extract the electric pump and clean it
	The pump's delivery rate is higher than the limit specified on the rating plate	Partially close the on-off valve located downstream until the delivery rate returns to within the specified limits
	The temperature of the sucked liquid is too high	Check the operating conditions of the electric pump.
	Worn motor bearings	Contact our Sales and Service Department
The electric pump starts up but does not deliver the required flow	Wrong rotation direction (three-phase version)	Check the direction of rotation and, if necessary, exchange two phases in the motor or electrical panel
	Pump is not primed because not filled with water	Repeat the priming procedure
	Pump not primed due to tightness failure in check valve	Check the check valve for perfect tightness
	Air in the pipes or pump	Bleed the air
	Piping and/or pump clogged	Disassemble and clean
	Well water level has dropped too much	Wait for water level to rise or, if possible, lower the electric pump further
	Pump capacity too high for well	Replace the pump with a lower capacity one
	Worn pump	Extract the pump and overhaul it
The system's general protection cuts in.	Short circuit	Check the electrical system
The system's differential thermal-magnetic protection cuts in.	Ground leakage.	Check insulation of the electrical system components
The pump rotates in the wrong direction when it is stopped.	Leaks in check valve	Repair or replace the components
The pump starts up too frequently	Leaks in check valve or system	Check and locate leaks. Repair or replace the components
	Ruptured membrane or no air pre-charge in surge tank	See relevant instructions in surge tank's manual
The pump starts up too frequently	Well water level has dropped too much	Wait for water level to rise or, if possible, lower the electric pump further
	Pump capacity too high for well	Replace the pump with a lower capacity one

9. Disposal

Information for installation and maintenance personnel



Observe the regulations and codes locally in force regarding sorted waste disposal.

10. Tabelle e disegni - Tables and Drawings - Tableaux et dessins - Tabellen und Zeichnungen - Tablas y dibujos - Tabelas e desenhos - Πίνακες και σχέδια - Tabellen en tekeningen - Tabeller og tegninger - Tabeller og tegninger - Tabeller och ritningar - Taulukot ja kaaviot - جداول وتصميمات - Tabele i Schematy - Táblázatok és ábrák - Таблицы и Чертежи - Tablolar ve çizimler

10.1 Come leggere la targa dati - How to Read the Rating Plate - Comment lire la plaque des données - Lesen des Datenschildes - Cómo leer la placa de características - Como ler a placa de características - Πώς διαβάζεται η πινακίδα στοιχείων - Wijze waarop het typeplaatje gelezen moet worden - Læsning af pumpens typeskilt - Hvordan lese dataskiltet - Pumpens märkplåt - Pumpun arvokilven tulkinta - كيفية قراءة ملصق البيانات - Jak czytać tabliczkę znamionową - Hogyan kell az adattáblát értelmezni - Обозначения на табличке - Veri plakasını nasıl okumak gerekir

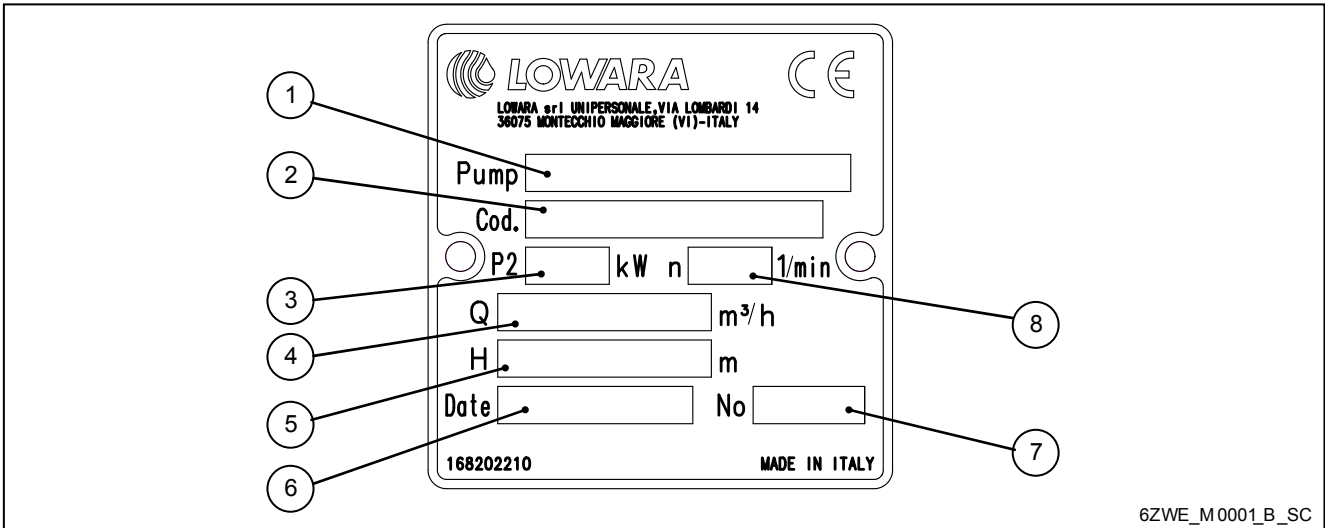

6ZWE_M0001_B_SC

1	Tipo pompa / elettropompa
2	Codice
3	Potenza nominale
4	Campo della portata
5	Campo della prevalenza*
6	Data di produzione
7	Numero di serie
8	Velocità
*	per l'acqua 10 metri di prevalenza equivalgono a quasi 1 bar (circa 100 kPa)

1	Pump/electric pump type
2	Code
3	Rated power
4	Flow range
5	Head range*
6	Manufacturing date
7	Serial number
8	Speed
*	For water, 10 meters of head correspond to almost 1 bar (approx. 100 kPa)

1	Type de pompe / électropompe
2	Code
3	Puissance nominale
4	Plage de débit
5	Plage de hauteur d'élevation *
6	Date de production
7	Numéro de série
8	Vitesse
*	Pour l'eau 10 mètres de hauteur d'élevation équivalent à presque 1 bar (environ 100 kPa)

1	Typ Pumpe/Motorpumpe
2	Code
3	Nennförderleistung
4	Förderleistungsbereich
5	Förderhöhenbereich*
6	Herstellungsjahr
7	Baureihennummer
8	Geschwindigkeit
*	Für Wasser entsprechen 10 Meter Förderhöhe fast 1 bar (etwa 100 kPa)

1	Tipo de bomba / electrobomba
2	Código
3	Potencia nominal
4	Campo del caudal
5	Campo de la altura de elevación*
6	Fecha de producción
7	Número de serie
8	Velocidad
*	Para el agua 10 metros de altura de elevación equivalen a casi 1 bar (unos 100 kPa)

1	Tipo de bomba / electrobomba
2	Código
3	Potência nominal
4	Campo do débito
5	Campo da altura manométrica *
6	Data de produção
7	Número de série
8	Velocidade
*	Para a água, 10 metros de altura manométrica correspondem a quase 1 bar (aprox. 100 kPa)

1	Τύπος αντλίας/ηλεκτρικής αντλίας
2	Κωδικός
3	Ονομαστική ισχύς
4	Εύρος της παροχής
5	Εύρος του υδροστατικού ύψους *
6	Ημερομηνία παραγωγής
7	Αριθμός σειράς
8	Ταχύτητα
*	Για το νερό 10 μέτρα υδροστατικού ύψους ισοδυναμούν με περίπου 1 bar (περίπου 100 kPa)

1	Pumpe-/elektropumpe type
2	Kode
3	Nominel effekt
4	Kapacitetsområde
5	Område for stighøjde *
6	Produktionsdato
7	Serienummer
8	Hastighed
*	Med hensyn til vand svarer en stighøjde på 10 m til 1 bar (ca. 100 kPa)

1	Typ av pump/elpump
2	Kod
3	Märkeffekt
4	Kapacitetsområde
5	Tryckhöjdens område *
6	Tillverkningsdatum
7	Serienummer
8	Hastighet
*	10 m tryckhöjd för vatten motsvarar nästan 1 bar (ca. 100 kPa).

1	نوع المضخة/المضخة الكهربائية.
2	القدرة الشكلية.
3	مجال القدرة.
4	مدى الانتشار.
5	تاريخ الإنتاج.*
6	الطراز.
7	السرعة.
8	الرقم المسلسل.
*	كل 10 أمتار انتشاراً للماء يعادل 1 بار تقريباً (حوالي 100 kPa).

1	Elektromos szivattyú / szivattyú típus
2	Kódszám
3	Névleges teljesítmény
4	Kapacitás tartomány
5	Prevalencia tartomány*
6	Gyártási dátum
7	Szériaszám
8	Sebesség
*	a víznél 10 méteres prevalencia majdnem 1 bar-nak felel meg (kb. 100 kPa)

1	Pompa / elektrikli pompa tipi
2	Kod
3	Nominal güç
4	Debi aralığı
5	Basma yüksekliği aralığı*
6	Üretim tarihi
7	Seri numarası
8	Hız
*	Su ile ilgili olarak, 10 metre basma yüksekliği takriben 1 bar'a eşittir (takriben 100 kPa)

1	Type pomp / elektropomp
2	Code
3	Nominaal vermogen
4	Capaciteitsbereik
5	Opvoerhoogtebereik *
6	Productiedatum
7	Serienummer
8	Snelheid
*	Bij water: 10 meter opvoerhoogte stemt overeen met ongeveer 1 bar (circa 100 kPa)

1	Type pumpe/elektropumpe
2	Kode
3	Nominell effekt
4	Verdiområde for kapasitet
5	Verdiområde for sugehøyde *
6	Produksjonsdato
7	Serienummer
8	Hastighet
*	For vannet er 10 meter sugehøyde nesten lik 1 bar (ca. 100 kPa)

1	Pumpun / sähköpumpun tyyppi
2	Koodi
3	Nimellisteho
4	Virtausnopeusalue
5	Painekorkeusalue *
6	Valmistuspvm
7	Sarjanumero
8	Nopeus
*	Veden 10 metrin painekorkeus vastaa lähes 1 baaria (n. 100 kPa).

1	Typ pompy elektrycznej
2	Numer katalogowy
3	Moc znamionowa
4	Przepływ znamionowy
5	Znamionowa wysokość podnoszenia*
6	Data produkcji
7	Numer serii
8	Prędkość
*	Dla wody, 10 metrów wysokości podnoszenia odpowiada prawie 1 bar (ok. 100 kPa)

1	Тип насоса/электронасоса
2	Код
3	Номинальная мощность
4	Диапазон подачи
5	Диапазон напора*
6	Дата производства
7	Серийный номер
8	Скорость
*	Для воды: 10 метров напора соответствуют ~ 1 бару (или 100 kPa)

10.1.1 Sigle identificative - Identification codes - Code d'identification - Kennzeichen - Siglas de identificación - Siglas de identificação - Συμβολογραφίες ταυτοποίησης - Identificatiecodes - Betegnelser - Betegnelser - Beteckningar - Tunnuksed - دلالات الرموز - Kod identyfikacyjny - Azonosító jelzések - Код обозначения - Tanımlama kodları

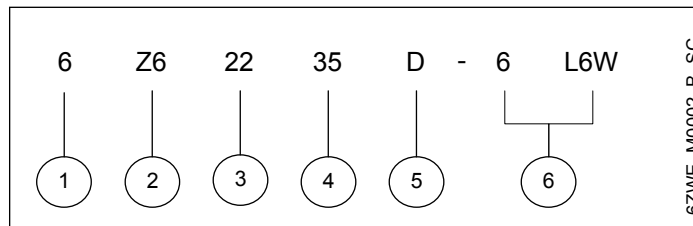

1	6 = 50 Hz 6 = 60 Hz
2	Z6 = Serie AISI 304 ZN6 = Serie AISI 316 ZR6 = Serie AISI 904
3	Portata nominale in m ³ /h
4	Numero stadi
5	= Versione base D = Versione alta prevalenza
6	Se solo pompa 4 = Flangia accoppiamento motore 4" 6 = Flangia accoppiamento motore 6" 8 = Flangia accoppiamento motore 8" Se elettropompa L6W = Sigla identificativa motore (esempio)

1	6 = 50 Hz 6 = 60 Hz
2	Z6 = AISI 304 series ZN6 = AISI 316 series ZR6 = AISI 904 series
3	Nominal flow rate in m ³ /h
4	Number of stages
5	= Basic version D = High head version
6	Pump only 4 = Motor coupling flange 4" 6 = Motor coupling flange 6" 8 = Motor coupling flange 8" Electric pump L6W = Motor identification code (example)

1	6 = 50 Hz 6 = 60 Hz
2	Z6 = Série AISI 304 ZN6 = Série AISI 316 ZR6 = Série AISI 904
3	Portée nominale en m ³ /h
4	Nombre d'étages
5	= Version de base D = Version à grande hauteur d'élévation
6	Si pompe uniquement 4 = Bride accouplement moteur 4" 6 = Bride accouplement moteur 6" 8 = Bride accouplement moteur 8" Si électropompe L6W = Sigle identification moteur (exemple)

1	6 = 50 Hz 6 = 60 Hz
2	Z6 = Baureihe AISI 304 ZN6 = Baureihe AISI 316 ZR6 = Baureihe AISI 904
3	Nennförderleistung in m ³ /h
4	Anzahl Stadien
5	= Basisversion D = Version hohe Förderhöhe
6	Nur Pumpe 4 = Kupplungsflansch Motor 4" 6 = Kupplungsflansch Motor 6" 8 = Kupplungsflansch Motor 8" Motorpumpe L6W = Kennzeichen Motor (Beispiel)

1	6 = 50 Hz 6 = 60 Hz
2	Z6 = Serie AISI 304 ZN6 = Serie AISI 316 ZR6 = Serie AISI 904
3	Caudal nominal en m ³ /h
4	Número de etapas
5	= Versión de base D = Versión con gran altura de elevación
6	Si hay sólo la bomba 4 = Brida de acoplamiento motor 4" 6 = Brida de acoplamiento motor 6" 8 = Brida de acoplamiento motor 8" En caso de electrobomba L6W = Sigla de identificación motor (ejemplo)

1	6 = 50 Hz 6 = 60 Hz
2	Z6 = Série AISI 304 ZN6 = Série AISI 316 ZR6 = Série AISI 904
3	Débito nominal em m ³ /h
4	Número de células
5	= Versão base D = Versão elevada altura manométrica
6	Se bomba 4 = Flange acoplamento motor 4" 6 = Flange acoplamento motor 6" 8 = Flange acoplamento motor 8" Se electrobomba L6W = Sigla de identificação do motor (exemplo)

1	6 = 50 Hz = 60 Hz
2	Z6 = Σειρά AISI 304 ZN6 = Σειρά AISI 316 ZR6 = Σειρά AISI 904
3	Ονομαστική παροχή σε m ³ /h
4	Αριθμός σταδίων
5	D = βασική έκδοση = έκδοση υψηλού υδροστατικού ύψους
6	Αν πρόκειται μόνο για αντλία 4 = Φλάντζα σύζευξης κινητήρα 4" 6 = Φλάντζα σύζευξης κινητήρα 6" 8 = Φλάντζα σύζευξης κινητήρα 8" Αν πρόκειται μόνο για ηλεκτρική αντλία L6W = Συντομογραφία ταυτοποίησης κινητήρα (παράδειγμα)

1	6 = 50 Hz = 60 Hz
2	Z6 = Serie AISI 304 ZN6 = Serie AISI 316 ZR6 = Serie AISI 904
3	Nominale opbrengst in m ³ /h
4	Aantal trappen
5	D = Basismodel = Model met hoge opvoerhoogte
6	Indien alleen pomp 4 = Motorverbindingsflens 4" 6 = Motorverbindingsflens 6" 8 = Motorverbindingsflens 8" Indien elektropomp L6W = Identificatiecode van de motor (voorbeeld)

1	6 = 50 Hz = 60 Hz
2	Z6 = Serie AISI 304 ZN6 = Serie AISI 316 ZR6 = Serie AISI 904
3	Nominel kapacitet udtrykt i m ³ /t
4	Antal trin
5	D = Standardversion = Version med høj stigeøjde
6	Kun pumpe 4 = Forbindelsesflange til motor 4" 6 = Forbindelsesflange til motor 6" 8 = Forbindelsesflange til motor 8" Kun elektropumpe L6W = Motorens betegnelse (eksempel)

1	6 = 50 Hz = 60 Hz
2	Z6 = Serie AISI 304 ZN6 = Serie AISI 316 ZR6 = Serie AISI 904
3	Nominell kapacitet i m ³ /h
4	Antall trinn
5	D = Standardutgave = Utgave for høy sugehøyde
6	Kun pumpe 4 = Koplingsflens for 4" motor 6 = Koplingsflens for 6" motor 8 = Koplingsflens for 8" motor Elektropumpe L6W = Motorens betegnelse (eksempel)

1	6 = 50 Hz = 60 Hz
2	Z6 = Serie AISI 304 ZN6 = Serie AISI 316 ZR6 = Serie AISI 904
3	Märkkapacitet i m ³ /tim
4	Antal steg
5	D = Standardversion = Version för hög tryckhöjd
6	Endast pump 4 = Kopplingsfläns för 4" motor 6 = Kopplingsfläns för 6" motor 8 = Kopplingsfläns för 8" motor Elpump L6W = Motorbeteckning (exempel)

1	6 = 50 Hz = 60 Hz
2	Z6 = Sarja AISI 304 ZN6 = Sarja AISI 316 ZR6 = Sarja AISI 904
3	Nimellisvirtausnopeus m ³ /h
4	Vaihemäärä
5	D = Perusversio = Korkean painekorkeuden versio
6	Pumppu 4 = Moottorin 4" liitoslaippa 6 = Moottorin 6" liitoslaippa 8 = Moottorin 8" liitoslaippa Sähköpumppu L6W = Moottorin tunnus (esimerkki)

1	50 هرتز = 60 هرتز = 6
2	AISI 304 طراز = Z6 AISI 316 طراز = ZN6 AISI 904 طراز = ZR6
3	القدرة الاسمية مقدرة بالمتر المكعب/ ساعة
4	عدد المساحات
5	طراز معياري = طراز انتشار قوي = D
6	للمضخة فقط 4 = زوائد تثبيت المحرك 4 بوصة 6 = زوائد تثبيت المحرك 6 بوصة 8 = زوائد تثبيت المحرك 8 بوصة للمضخة الكهربائية L6W = رمز يشير للمحرك (كمثال)

1	= 50 Hz 6 = 60 Hz
2	Z6 = AISI 304 sorozat ZN6 = AISI 316 sorozat ZR6 = AISI 904 sorozat
3	Névleges áramlási sebesség m ³ /h-ban
4	Szakaszok száma
5	= alap változat D = magas prevalencia változat
6	Csak szivattyú 4 = 4"-os motorkapcsoló-karima 6 = 6"-os motorkapcsoló-karima 8 = 8"-os motorkapcsoló-karima Elektronos szivattyú L6W = motorazonosító kód (példa)

1	= 50 Hz 6 = 60 Hz
2	Z6 = AISI 304 serisi ZN6 = AISI 316 serisi ZR6 = AISI 904 serisi
3	Nominal debi (m ³ /saat)
4	Kademe sayısı
5	= Temel versiyon D = Büyük basma yükseklikli versiyon
6	Sadece pompa 4 = 4" motor bağlama flanşı 6 = 6" motor bağlama flanşı 8 = 8" motor bağlama flanşı Elektrikli pompa L6W = Motor tanımlama kodu (örnektir)

1	= 50 Hz 6 = 60 Hz
2	Z6 = seria AISI 304 ZN6 = seria AISI 316 ZR6 = seria AISI 904
3	Przepływ nominalny w m ³ /h
4	Ilość stopni
5	= Wersja podstawowa D = Wersja z dużą wysokością pompowania
6	Tylko pompa 4 = przyłącze silnika 4" 6 = przyłącze silnika 6" 8 = przyłącze silnika 8" Pompa elektryczna L6W = kod oznaczeń silnika (przykład)

1	= 50 Гц 6 = 60 Гц
2	Z6 = версия из AISI 304 ZN6 = версия из AISI 316 ZR6 = версия из AISI 904
3	Номинальная подача в м ³ /ч
4	Количество ступеней
5	= Базовая модель D = Модель с большой высотой напора
6	Только для насоса 4 = соединительный фланец двигателя 4" 6 = соединительный фланец двигателя 6" 8 = соединительный фланец двигателя 8" Электронасос L6W = Идентификационный код двигателя(пр)

10.2 Esempio di corretto immagazzinamento - Correct storage example - Exemple de stockage correct - Beispiel für die korrekte Einlagerung - Ejemplo de almacenamiento correcto - Exemplo de armazenagem correcta - Παράδειγμα σωστής αποθήκευσης - Voorbeeld van correcte opslag - Eksempel på korrekt opbevaring - Eksempel på riktig lagring - Exempel på korrekt förvaring - Esimerkki oikeasta varastoinnista - مثال للتخزين الصحيح - Przykład poprawnego przechowywania - Példa a helyes tárolásra - Правильный способ хранения - Doğru depolama örneği

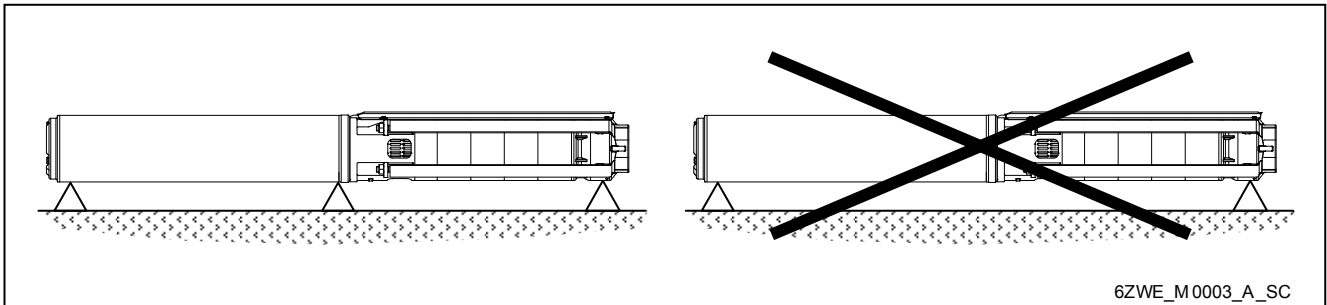

10.3 Modalità corretta di movimentazione - Correct handling method - Modalité de manutention correcte - Korrektes Handlingsverfahren - Modalidad correcta de desplazamiento - Modalidade correcta de movimentação - Τρόπος σωστής μετακίνησης - Correcte verplaatsingsmethode - Korrekt fremgangsmåde ved flytning - Riktig håndtering - Korrekt flytt - Oikea liikutustapa - الطريقة المثلى للتحرك - Metoda poprawnego zawieszania - Helyes mozgatási módokat - Правильный способ транспортировки - Doğru taşıma örneği

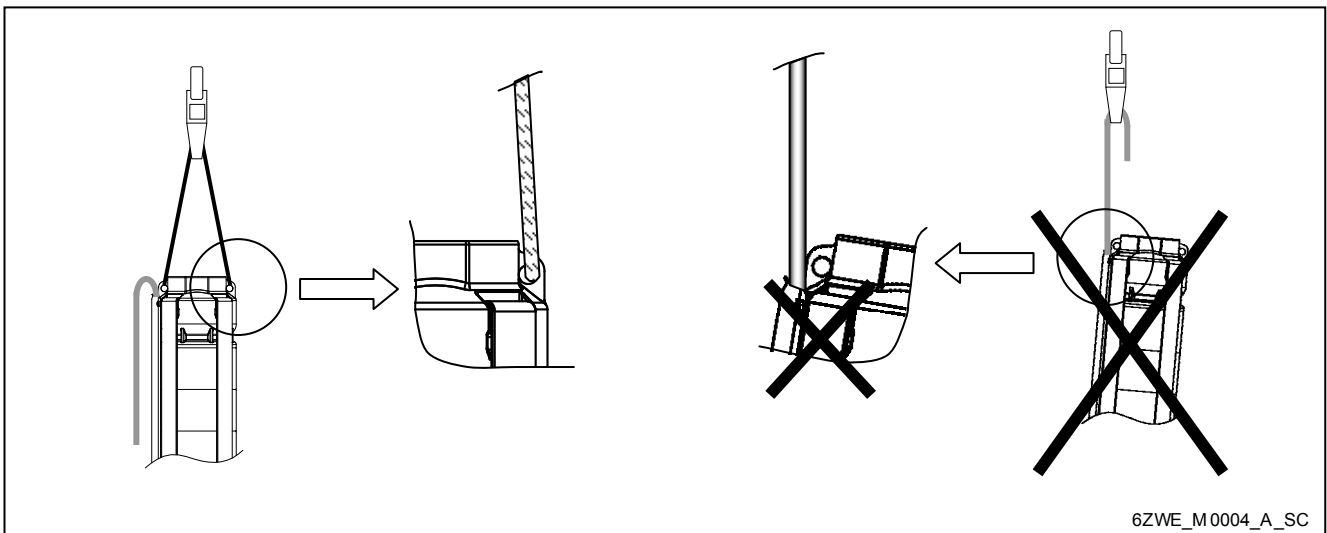

10.4 Esempio di installazione - Installation example - Exemple d'installation - Installationsbeispiel - Ejemplo de instalación - Exemplo de instalação - Παράδειγμα εγκατάστασης - Installatievoorbeeld - Eksempel på installation - Eksempel på installasjon - Installationsexempel - Asennusesimerkki - مثال للتثبيت - Przykład poprawnego montażu - Telepítési példa - Пример установки - Montaj örneği

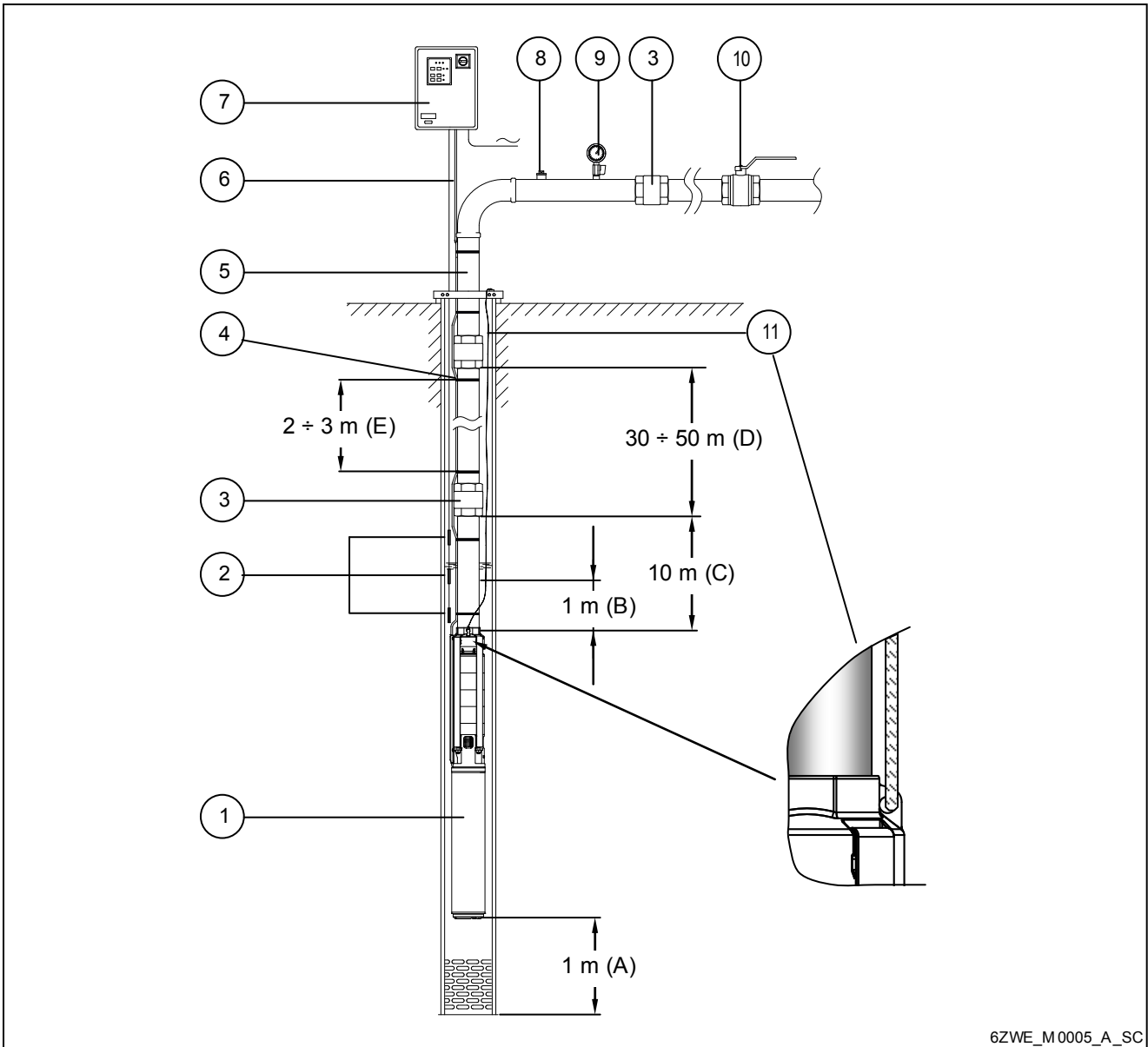

6ZWE_M0005_A_SC

1	Elettropompa sommersa
2	Sonde di livello per la protezione contro la marcia a secco
3	Valvola di non ritorno
4	Fascetta di fissaggio del cavo elettrico di discesa sul tubo di mandata
5	Tubazione di mandata
6	Cavo elettrico di discesa
7	Quadro di comando
8	Tappo per sfiato / adescamento pompa
9	Manometro
10	Valvola di intercettazione
11	Fune di sicurezza (specialmente quando il tubo di mandata è di materiale plastico o flessibile)
A	Distanza minima tra il fondo del pozzo e l'elettropompa
B	Minimo livello dinamico da garantire sopra la bocca di mandata della pompa
C	Distanza tra la bocca di mandata della pompa e la

1	Submersible electric pump
2	Level sensors for protection against dry running
3	Non-return valve
4	Clamp fastening the electric drop cable to the delivery pipe
5	Delivery piping
6	Electric drop cable
7	Control panel
8	Air / pump priming plug
9	Pressure gauge
10	On-off valve
11	Safety cable (especially needed when the delivery pipe is made of plastic or flexible material)
A	Minimum distance between the bottom of the well and the electric pump
B	Minimum dynamic level above the pump's delivery port
C	Distance between the pump's delivery port and the

	prima valvola di non ritorno
D	Distanza tra le successive valvole di non ritorno
E	Distanza tra le fascette di fissaggio del cavo elettrico di discesa al tubo di mandata

	first non-return valve
D	Distance between the subsequent non-return valves
E	Distance between the clamps that fasten the electric drop cable to the delivery pipe

1	Electropompe immergée
2	Capteur de niveau pour la protection contre la marche à sec.
3	Clapet antiretour
4	Collier de fixation du câble de descente sur le tuyau de refoulement
5	Canalisation de refoulement
6	Câble électrique de descente
7	Tableau de commande
8	Bouchon pour vidange / amorçage pompe
9	Manomètre
10	Robinets d'arrêt
11	Câble de sécurité (notamment lorsque le tuyau de refoulement est en matière plastique flexible)
A	Distance minimale entre le fond du puits et l'électropompe
B	Niveau minimal à garantir au dessus de la bouche de refoulement de la pompe
C	Distance entre la bouche de refoulement et le clapet antiretour
D	Distance entre les autres clapets de nonretour
E	Distance entre les colliers de fixation du câble de descente et le tuyau de refoulement

1	Tauchmotorpumpe
2	Niveausonde für den Schutz gegen Trockenlauf
3	Rückschlagventil
4	Befestigungsschelle des Abstiegskables an der Druckleitung
5	Druckleitung
6	Abstiegsstromkabel
7	Bedientafel
8	Entlüftungsstutzen-/Einfüllstutzen Pumpe
9	Manometer
10	Sperrventil
11	Sicherheitsseil (insbesondere, wenn die Druckrohrleitung aus Kunststoff oder ein Schlauch ist)
A	Abstand zwischen Brunnengrund und Motorpumpe
B	Dynamisches Mindestpegel, der über dem Druckstutzen der Pumpe zu garantieren ist
C	Abstand zwischen dem Druckstutzen der Pumpe und dem ersten Rückschlagventil
D	Abstand zwischen den darauf folgenden Rückschlagventilen
E	Abstand zwischen den Befestigungsschellen des Abstiegsstromkabels zur Druckleitung

1	Electrobomba sumergible
2	Sondas de nivel para la protección contra la marcha en seco
3	Válvula de retención
4	Abrazadera de fijación del cable eléctrico de descenso en el tubo de impulsión
5	Tubería de impulsión
6	Cable eléctrico de descenso
7	Cuadro de mando
8	Tapón de purga / cebado bomba
9	Manómetro
10	Válvula de cierre
11	Cable de seguridad (sobre todo cuando el tubo de impulsión es de material plástico o flexible)
A	Distancia mínima entre el fondo del pozo y la electrobomba
B	Nivel dinámico mínimo que se debe garantizar sobre la boca de impulsión de la bomba
C	Distancia entre la boca de impulsión de la bomba y la primera válvula de retención
D	Distancia entre las válvulas de retención siguientes
E	Distancia entre las abrazaderas de fijación del cable eléctrico de descenso en el tubo de impulsión

1	Electrobomba submersível
2	Sondas de nível para a protecção contra o funcionamento em seco
3	Válvula anti-retorno
4	Braçadeira de fixação do cabo eléctrico de descida no tubo de compressão
5	Tubo de compressão
6	Cabo eléctrico de descida
7	Quadro de comando
8	Tampão para drenagem / ferragem da bomba
9	Manómetro
10	Válvula de corte
11	Corda de segurança (especialmente com tubo de compressão de material plástico ou flexível)
A	Distância mínima entre o fundo do furo e a electrobomba
B	Mínimo nível dinámico a garantir por cima da boca de compressão da bomba
C	Distância entre a boca de compressão da bomba e a primeira válvula anti-retorno
D	Distância entre as sucessivas válvulas anti-retorno
E	Distância entre as braçadeiras de fixação do cabo eléctrico de descida no tubo de compressão

1	Βυθιζόμενη ηλεκτρική αντλία
2	Αισθητήρες στάθμης για την προστασία από κίνηση χωρίς φορτίο
3	Ανεπίστροφη βαλβίδα
4	Λωρίδα στερέωσης του ηλεκτρικού καλωδίου καθόδου στο σωλήνα προσαγωγής
5	Σωλήνωση προσαγωγής
6	Ηλεκτρικό καλώδιο καθόδου
7	Πίνακας χειρισμού
8	Πώμα για απαέρωση/πλήρωση αντλίας

1	Elektrodompelpomp
2	Niveausondes ter bescherming tegen drooglopen
3	Terugslagklep
4	Bevestigingsklem elektrische neerlaatkabel op persleiding
5	Persleiding
6	Elektrische neerlaatkabel
7	Schakelkast
8	Ontluchtungs-/pompprimingsplug

9	μανόμετρο
10	Βαλβίδα ανάσχεσης
11	Σύρμα ασφαλείας (ειδικά όταν ο σωλήνας προσαγωγής είναι από πλαστικό ή εύκαμπτο υλικό)
A	Ελάχιστη απόσταση μεταξύ του βάθους του πηγαδιού και της ηλεκτρικής αντλίας
B	Ελάχιστη στάθμη που πρέπει να διασφαλιστεί πάνω από το στόμιο προσαγωγής της αντλίας
C	Απόσταση μεταξύ του στομίου προσαγωγής της αντλίας και της πρώτης ανεπίστροφης βαλβίδας
D	Απόσταση μεταξύ των διαδοχικών ανεπίστροφων βαλβίδων
E	Απόσταση μεταξύ των λωρίδων στερέωσης του ηλεκτρικού καλωδίου καθόδου στο σωλήνα προσαγωγής

1	Dykelektropumpe
2	Niveausonder til beskyttelse mod at køre tør
3	Bakventil
4	Strop til fastgørelse af sænkekabel på trykrør
5	Trykrør
6	Elektrisk sænkekabel
7	Kontrolpanel
8	Prop til udluftning/spædning af pumpe
9	Manometer
10	Afspærringsventil
11	Sikkerhedswire (specielt, hvis trykrøret er af plast eller er fremstillet af en slange)
A	Min. afstand mellem brøndens bund og elektropumpen
B	Dynamisk min. niveau (skal garanteres over pumpens trykstuds)
C	Afstand mellem pumpens trykstuds og den første bakventil
D	Afstand mellem de efterfølgende bakventiler
E	Afstand mellem stropper til fastgørelse af elektrisk sænkekabel på trykrør

1	Dränkbar elpump
2	Nivåsonder för skydd mot torrkörning
3	Backventil
4	Bandklamma för fastsättning av nedsänkingskabel på tryckröret
5	Tryckrör
6	Nedsänkingskabel
7	Manöverpanel
8	Plugg för avluftning/fyllning av pump
9	Manometer
10	Avstängningsventil
11	Säkerhetsvajer (krävs speciellt när tryckröret är av plast eller är en slang).
A	Min. avstånd mellan brunnens botten och elpump
B	Erforderlig min. dynamisk vätskenivå ovanför pumpens tryckutlopp
C	Avstånd mellan pumpens tryckutlopp och den första backventilen
D	Avstånd mellan övriga backventiler
E	Avstånd mellan bandklammorna för fastsättning av nedsänkingskabel på tryckröret

9	Manometer
10	Afsluitklep
11	Veiligheidskabel (met name als de perssling van kunststof materiaal of buigzaam is)
A	Minimum afstand tussen de bodem van de put en de elektropomp
B	Minimum dynamisch niveau dat boven de persopening van de pomp gegarandeerd moet worden
C	Afstand tussen de persopening van de pomp en de eerste balkeerklep
D	Afstand tussen de volgende balkeerklappen
E	Afstand tussen de bevestigingsklemmen van de elektrische neerlaatkabel op persleiding

1	Nedsenkbar elektropumpe
2	Nivåsonder for beskyttelse mot tørrkjøring
3	Tilbakeslagsventil
4	Festeklemme for den elektriske senkekabelen på trykkrøret
5	Trykkør
6	Elektrisk senkekabel
7	Kontrolltavle
8	Plugg for luftutslipp/fylling av pumpen
9	Manometer
10	På/av ventil
11	Sikkerhetstau (spesielt ved bruk av plastrør eller slanger)
A	Min. avstand mellom brønnbunnen og elektropumpen
B	Min. dynamiske nivå som må garanteres over pumpens trykkåpning
C	Avstand mellom pumpens trykkåpning og den første tilbakeslagsventilen
D	Avstand mellom de neste tilbakeslagsventilene
E	Avstand mellom festeklemme for den elektriske senkekabelen på trykkrøret

1	Upposähköpumppu
2	Kuivakäynnin estänyt tasoanturit
3	Takaiskuventtiili
4	Laskusähkökaapelin poistoputkeen liitävät kiinnittimet
5	Poistoputki
6	Laskusähkökaapeli
7	Sähkötaulu
8	Pumpun ilmaus- ja täyttöputka
9	Painemittari
10	Sulkuventtiili
11	Turvavaijeri (erityisesti, jos poistoputki on muovia tai letku)
A	Kaivon pohjan ja sähköpumpun välinen minimietäisyys
B	Pumpun poistoaukon yläpuolelle taattava dynaaminen minimitaso
C	Pumpun poistoaukon ja ensimmäisen takaiskuventtiilin välinen etäisyys
D	Muiden takaiskuventtiilien välinen etäisyys
E	Laskusähkökaapelin poistoputkeen liitävien kiinnittimien välinen etäisyys

1	المضخة الكهربائية المغمورة.
2	مسابر المستوى للحماية ضد التشغيل على الجاف.
3	صمام ضد الارتجاع.
4	رباط التثبيت لكابيل الكهرباء الذي يركب على ماسورة الضخ.
5	ماسورة الضخ.
6	كابل الكهرباء المنحدر.
7	اللوحة الكهربائية.
8	صمام التفريغ/ضخ المضخة.
9	جهاز قياس الضغط.
10	صمام الإغلاق.
11	كابل الامان (خاصة عندما تكون ماسورة الضخ مصنوعة من مادة بلاستيكية أو أي مادة مرنة).
A	أدنى مسافة بين عمق البئر والمضخة الكهربائية.
B	أقل مستوى ديناميكي يمكن ضمانه فوق فوهة الضخ.
C	المسافة بين فوهة الضخ للمضخة وأول صمام ضد الارتجاع.
D	المسافة بين صمامات عدم الارتجاع.
E	المسافة بين زوائد تثبيت كابل الكهرباء الذي سينحدر على ماسورة الضخ.

1	Merülő elektromos szivattyú
2	Szint szondák a száraz járat elleni védelemhez
3	Visszacsapószelep
4	A leereszkedő elektromos vezeték a szállítócsőre rögzítő pánt
5	Szállító csővezeték
6	Leereszkedő elektromos vezeték
7	Vezérlő kapcsolótábla
8	Légtelenítő dugó/ szivattyú indítás
9	Manométer
10	Zárószelep
11	Biztonsági kötél (különösen amikor a szállítócső műanyag, vagy rugalmas anyagból készül)
A	A kút alja és az elektromos szivattyú közötti minimális távolság
B	Minimális biztosítandó dinamikus szint a szivattyú szállítónyílása fölött
C	A szivattyú szállítónyílása és az első visszacsapószelep közötti távolság
D	Távolság a további visszacsapószelepek között
E	A leereszkedő elektromos vezeték a szállítócsőre rögzítő pántok közötti távolság

1	Elektrikli dalgıç pompa
2	Kuru çalışmaya karşı koruyucu seviye problemi
3	Geri dönüşsüz valf
4	Elektrik inış kablosunu basma borusuna sabitleme tutucusu
5	Basma borusu
6	Elektrik inış kablosu
7	Elektrik kumanda panosu
8	Pompa boşaltma/havasızlandırma tapası
9	Manometre
10	Açma-kapama valfi
11	Emniyet halatı (özellikle basma borusu plastik ya da esnek malzemededen yapılmış olduğunda)
A	Kuyunun dibi ile elektrikli pompa arasındaki minimum mesafe

1	Głębiniowa pompa elektryczna
2	Sondy poziomu dla zabezpieczenia przed suchobiegiem
3	Zawór zwrotny
4	Obejmy mocujące kabel zasilający do rurociągu tłocznego
5	Rurociąg tłoczny
6	Elektryczny kabel zasilający
7	Elektryczna skrzynka sterownicza
8	Korek odpowietrzający/zalewowy pompy
9	Manometr
10	Zawór odcinający
11	Linka zabezpieczająca (szczególnie niezbędna gdy rurociąg tłoczny jest wykonany z plastiku lub materiału elastycznego)
A	Minimalna odległość pomiędzy dnem studni a pompą
B	Minimalny poziom lustra dynamicznego nad króćcem tłocznym pompy
C	Odległość pomiędzy króćcem tłocznym pompy a pierwszym zaworem zwrotnym na rurociągu
D	Odległość pomiędzy poszczególnymi zaworami zwrotnymi
E	Odległość pomiędzy obejmami mocującymi kabel zasilający silnika do rurociągu tłocznego

1	Погружной электронасос
2	Датчики уровня для защиты от сухого хода
3	Обратный клапан
4	Хомут, крепящий электрокабель к напорному трубопроводу
5	Напорный патрубок
6	Электрический кабель
7	Шкаф управления
8	Воздушник / пробка заполнения насоса
9	Манометр
10	Запорный клапан
11	Защитный кабель (необходим в случае, когда напорный трубопровод выполнен из пластика или гибкого материала)
A	Минимальное расстояние от дна скважины до электрического насоса
B	Минимальный динамический уровень над выходным патрубком насоса
C	Расстояние между выходным патрубком насоса и первым обратным клапаном
D	Расстояние между последовательно установленными обратными клапанами
E	Расстояние между хомутами, крепящими электрокабель к напорному трубопроводу

B	Pompanın basma ağızının üstündeki minimum dinamik seviye
C	Pompanın basma ağızı ile birinci geri dönüşsüz valf arasındaki mesafe
D	Müteakip geri dönüşsüz valfler arasındaki mesafeler
E	Elektrik inış kablosunu basma borusuna sabitleme tutucuları arasındaki mesafe

10.5 **Tabella coppie di serraggio (accoppiamento flangia motore con supporto inferiore pompa) - Driving torque table (motor flange coupling with pump lower support) - Tableau des couples de serrage (accouplement bride moteur et support inférieur de la pompe) - Tabelle der Anzugsmomente (Ankuppeln des Motorflansches mit der unteren Pumpenhalterung) - Tabla de pares de apriete (acoplamiento brida motor con adaptator) - Tabela dos binários de aperto (acoplamento flange motor com suporte inferior bomba) - Πίνακας ροπών σύσφιξης (σύζευξη φλάντζας κινητήρα με κάτω φορέα αντλίας) - Tabel aanhaalkoppels (verbinding motorflens met onderste pompsteun) - Tabel over tilspændingsmomenter (sammenkobling mellem motorens flange og pumpens nederste støtte) - Tabell over strammemoment (kopplingsflens for motor med pumpens nederste støtte) - Tabell över åtdragningsmoment (motorflänsens anslutning med pumpens nedre stöd) - Vääntömomenttitaulukko (moottorin laipan kytkentä pumpun alakannattimeen) - Таблица значений крутящих моментов (соединение фланца двигателя с нижней опорой насоса) - Tabela momentu dokręcania (połączenie kołnierza silnika z dolnym wspornikiem pompy) - Rögzítési nyomaték táblázat (a motor karima szivattyú alsó tartóegységével történő összekapcsolása) - جدول عزم المحرك (توصيل دعامة المحرك مع الدعامة السفلية للمضخة) - Tabela momentu dokręcania (połączenie kołnierza silnika z dolnym wspornikiem pompy) - Rögzítési nyomaték táblázat (a motor karima szivattyú alsó tartóegységével történő összekapcsolása) - Таблица значений крутящих моментов (соединение фланца двигателя с нижней опорой насоса) - Sıkma torkları tablosu (motor flansının alt pompa mesnedi ile bağlanması)**

		A		
		4"	6"	8"
B	Φ	M 8	M 12	M16
	Nm	15	65	100
CH		13	19	24

6ZWE_M0006_A_sc

A	Grandezza motore
B	Tirante / vite motore
Φ	Diametro
Nm	Coppia di serraggio

A	Motor size
B	Motor
Φ	Diameter
Nm	Driving torque

A	Taille moteur
B	Tringles / vis moteur
Φ	Diamètre
Nm	Couple de serrage

A	Motorgröße
B	Motor-Zugstange / -schraube
Φ	Durchmesser
Nm	Anzugsmoment

A	Tamaño motor
B	Tirante / tornillo motor
Φ	Diámetro
Nm	Par de apriete

A	Grandezza motor
B	Tirante / parafuso motor
Φ	Diámetro
Nm	Binário de aperto

A	Μέγεθος κινητήρα
B	Συνδετική ράβδος / βίδα κινητήρα
Φ	Διάμετρος
Nm	Ροπή σύσφιξης

A	Motorgrootte
B	Trekstang / motorschroef
Φ	Diameter
Nm	Aanhaalkoppel

A	Motorens størrelse
B	Trækstang/skrue til motor
Φ	Diameter
Nm	Tilspændingsmoment

A	Motorstørrelse
B	Motorstag/-skrue
Φ	Diameter
Nm	Strammemoment

A	Motorstorlek
B	Dragstag/skruv för motor
Φ	Diameter
Nm	Åtdragningsmoment

A	Moottorin koko
B	Moottorin vetotanko / ruuvi
Φ	Halkaisija
Nm	Vääntömomentti

A	أبعاد المحرك
B	المسمار اللولبي للمحرك / الدعامة
Φ	القطر
Nm	عزم المحرك

A	Wielkość silnika
B	Drażek kierowniczy / śruba silnika
Φ	Średnica
Nm	Moment dokręcania

A	Motor nagyság
B	Kereszttartó / motor csavar
Φ	Átmérő
Nm	Rögzítési nyomaték

A	Величина двигателя
B	Тяга / винт двигателя
Φ	Диаметр
Nm	Крутящий момент

A	Motor boyutu
B	Motor gergisi / civatası
Φ	Çap
Nm	Sıkma torku

it Lowara si riserva il diritto di apportare modifiche senza obbligo di preavviso.
en **Lowara reserves the right to make modifications without prior notice.**
fr Lowara se réserve le droit d'apporter des modifications sans obligation de préavis.
de Änderungen, auch ohne vorherige Ankündigung, sind LOWARA jederzeit vorbehalten.
es Lowara se reserva el derecho de realizar modificaciones sin necesidad de aviso previo.
pt A Lowara reserva-se o direito de proceder a alterações sem aviso prévio.
nl Lowara behoudt zich het recht voor om zonder voorafgaand bericht wijzigingen aan te brengen.
da Lowara forbeholder sig retten til at ændre specifikationerne uden meddelelse herom.
no Lowara forbeholder seg retten til å utføre endringer uten forvarsel.
sv Lowara förbehåller sig rätten att utföra ändringar utan förhandsmeddelande.
fi Lowara pidättää itselleen oikeuden tehdä muutoksia ilman ennakoilmoitusta.
is Lowara áskilur sér rétt til að gera breytingar án fyrirvara.
et Lowara jätab endale õiguse teha muudatusi eelnevalt ette teatamata
lv Lowara patur tiesības veikt izmaiņas bez iepriekšēja brīdinājuma.
lt „Lowara“ pasilieka teisę atlikti pakeitimus be išankstinio įspėjimo.
pl Lowara zastrzega sobie prawo do wprowadzenia zmian bez obowiązku wcześniejszego powiadomienia.
cs Společnost Lowara si vyhrazuje právo na provedení změn bez předcházejícího upozornění.
sk Spoločnosť Lowara si vyhradzuje právo na vykonanie zmien bez predchádzajúceho upozornenia.
hu A Lowara fenntartja magának a jogot előzetes értesítés nélküli módosítások eszközésére.
ro Lowara își rezervă dreptul de a face modificări fără o înștiințare prealabilă.
bg Фирмата Ловара си запазва правото да нанася промени без предупреждение
sl Lowara si pridržuje pravico do vnašanja sprememb brez vsakršnega predhodnega obvestila.
hr Lowara zadržava pravo promjene bez obaveze prethodne najave.
sr Lowara zadržava pravo promene bez obaveze prethodne najave.
el Η Lowara διατηρεί το δικαίωμα να επιφέρει τροποποιήσεις χωρίς υποχρέωση προειδοποίησης
tr Lowara şirketi önceden haber vermeksizin değişiklikler yapma hakkını saklı tutmaktadır
ru Lowara оставляет за собой право вносить изменения без предварительного уведомления.
uk Компанія Lowara залишає за собою право вносити зміни без попередження.
ar تحتفظ شركة لوارا Lowara بحق إجراء تعديلات بدون الالتزام بالتنبيه المسبق.