

# Shallow Well Cast Iron Jet Pumps

## CA/CAM Series



The Speroni CA/CAM self-priming jet pumps are built for applications where the water source suction lift is up to 8 metres. The CAM range is suitable for tank, well, river or dam applications. European build quality ensures high performance in the toughest environments.



### Applications

- Domestic rainwater supply
- Industrial water supply
- Stock water supply
- Dairy washdown
- Irrigation
- Water transfer
- Pressure boosting

### Key Features

- 304 Stainless Steel impeller
- Robust cast iron pump casing
- Single-phase or Three-phase IP55 motor - made in Italy
- Inbuilt thermal protection
- IP44 Pressure Switch fitted on both the Single-phase and Three-phase models
- Plug and Play leads
- Available as a pressure system or as a standalone bare pump
- 2 year warranty

### Materials of Construction

- Pump body: Cast iron
- Motor support: Cast iron
- Impeller: 304 Stainless Steel
- Diffuser: Noryl
- Shaft with rotor: Stainless steel AISI 304
- Mechanical seal: Ceramic/Graphite/NBR

### Operating Conditions

- Maximum liquid temperature: 35°C
- Ambient temperature: Up to 40°C
- Total suction lift: Up to 8m
- Continuous duty

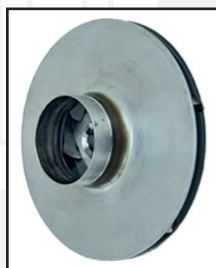

Impeller

### Motor

- Single-phase 240V-50Hz
- Three-phase 230/400-50Hz
- Two-Pole induction motor (2850 RPM)
- Insulation Class F
- Protection IP55

### Also available as a pressure system

The CA/CAM302 Jet Pumps are available in both Single-phase and Three-phase models. Three-phase models are available as a standalone bare pump or as a pressure system with Three-phase pressure switch, pressure gauge and 5-way tee.



Three-phase model

Model	Nominal Power		Input Power	Amps	Q = Capacity													
	P2		P1		Single-phase / Three-phase	m³/h	0,6	1,2	1,8	2,7	3,6	4,8	5,4	6	7,2	9	9,6	12
Single-phase / Three-phase	HP	kW	kW			lt/1'	10	20	30	45	60	80	90	100	120	150	160	200
CAM 302 / CA 302	3	2,2	3	13,5 / 5,2	Total head in meters w.c													
					H (m)	55	53	52	50	48	45	43	42	38	33	32	25	22

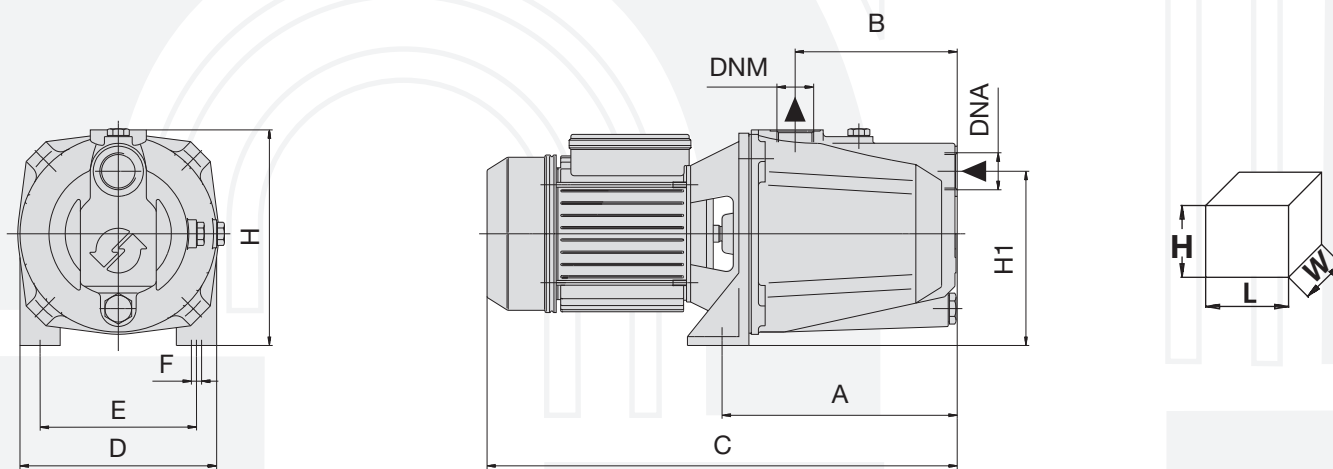
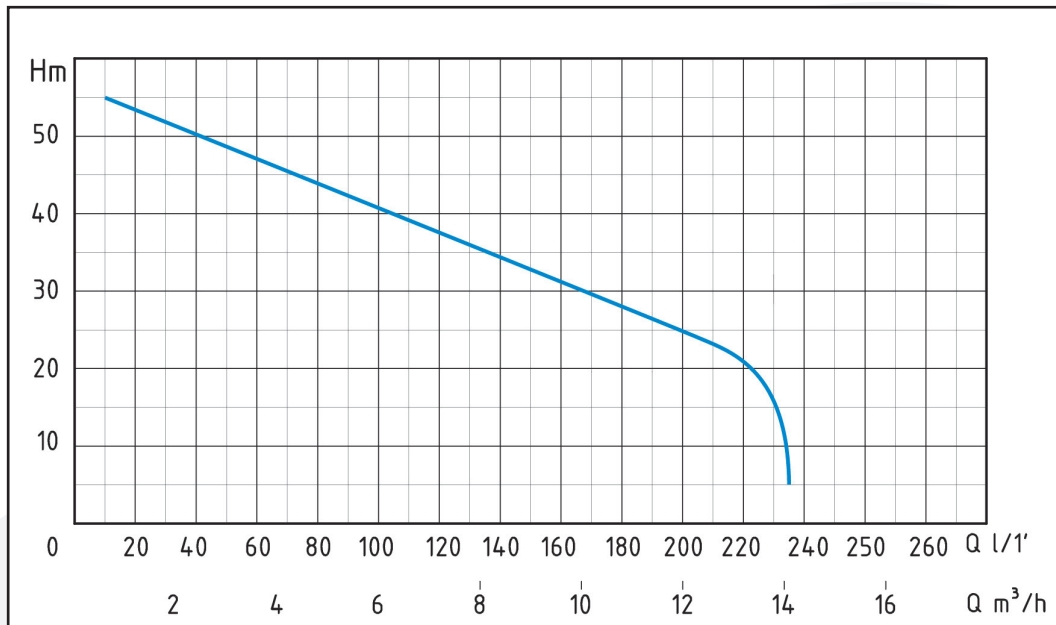

Model		Dimensions mm										Dimensions mm			Weight
Single-phase	Three-phase	A	B	C	D	E	F	H	H1	DNA	DNM	W	L	H	Kg
CAM 302	CA 302	290	174	570	225	166	12	230	183	1" ½	1" ¼	245	600	300	30

Dealer Details