

# AcquaSaver®



## Water Diversion Valve

Hydraulically Operated  
Solid Brass Construction  
Built-in Dual Check Valves

 [www.acquasaver.com.au](http://www.acquasaver.com.au)



WaterMark  
WMTS477  
LN60075

# AcquaSaver®

The AcquaSaver® Valve is a fully automatic mechanical rainwater/mains water changeover device designed for pressure pump supply systems for harvesting rainwater for the toilet, laundry and household applications with automatic mains backup.

It is suitable for up to 2 toilets and washing machine and an extra tap outlet.

## Features

- Easy to install
- Patent design
- Solid Brass mounting bracket (optional)
- Watermark approved to WMTS477/LN60075
- Does not require regular maintenance
- No electrical consumption - No electronic components
- Solid brass construction - Fully weatherproof - Built to last
- Suitable for any pressure pump with sufficient head pressure
- Can be mounted in any position
- Built-in dual check valve for backflow prevention
- 2 Year warranty



**WaterMark**

WMTS477  
LN60075

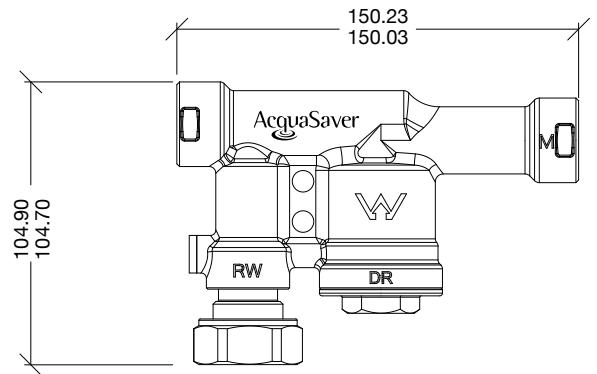

## Specifications

Max Mains Pressure	500 KPa
Max Pump Pressure	600 KPa
Min Pump Pressure	300 KPa
Max Flow Rate	50 LPM
Max Water Temperature	40 C
Min Water Temperature	0 C
Pump Inlet	25mm 1" BSP F
Mains Water in	20mm 3/4" BSP F
Outlet	20mm 3/4" BSP F
Weight	0.85 KG

Complies to WMTS477/LN60075 when installed by a licensed plumber.

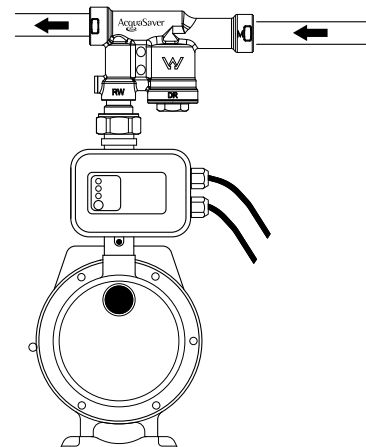

1300 4 BBENG  
www.brownbros.com.au



0508 4 BBENG  
www.brownbros.co.nz